

Original Instructions



FocusParameterMonitor FPM PROFINET

FocusParameterMonitor FPM

FPM 60, FPM 100, FPM 120, FPM 160
Hardware- und Softwareinterface PROFINET/PROFIBUS

IMPORTANT!

READ CAREFULLY BEFORE USE!

KEEP FOR FUTURE USE!

Table of contents

1	Basic safety notes	7
2	Symbols and conventions	8
3	About this operating manual	9
4	Device description	10
4.1	Type overview	10
4.2	Functional description	11
4.3	Measuring principle	12
4.4	Optical displays	13
4.4.1	FPM PROFIBUS	13
4.4.2	FPM PROFINET	13
4.4.3	FPM PROFINET M12	14
4.5	Scope of delivery and optional accessories	14
5	Transport and storage	14
6	Mounting	15
6.1	Conditions at the installation site	15
6.2	Installation in the laser system	15
6.2.1	Prepare mounting	15
6.2.2	Possible mounting positions	15
6.2.3	Align the device	16
6.2.4	Mount the device	16
6.3	Removal from the laser system	18
7	Connectors	19
7.1	FPM PROFIBUS	19
7.1.1	Interface description PROFIBUS	19
7.1.2	Set PROFIBUS address	20
7.1.3	Device master file (GSD file)	21
7.2	FPM PROFINET	22
7.2.1	Interface description PROFINET	22
7.2.2	Device master file (GSDML file)	23
7.3	FPM PROFINET M12	24
7.3.1	Interface description PROFINET M12	24
7.3.2	Device master file (GSDML file)	26
7.4	Locking device for interlock	26
7.5	Compressed air connection	27
8	PROFIBUS/PROFINET parameter set	28
8.1	Inputs	29
8.2	Outputs	33
8.3	Error identifier	35
8.3.1	Error identifier hardware	35
8.3.2	Error identifier parameter selection	35
8.3.3	Error identifier single plane measurement	36
8.3.4	Error identifier caustic	36
8.3.5	Warning identifier single plane measurement	37
8.3.6	Warning identifier caustic	37
9	Install and configure LDS	38
9.1	System requirements	38
9.2	Install software	38
9.3	Ethernet configuration	39
9.3.1	Set IP address of PC	39

9.3.2	Change IP address of a connected device	39
9.3.3	Establishing a connection to FPM	40
9.3.4	Obtain an IP address automatically with DHCP	41
10	Description of the LDS	42
10.1	Graphical user interface.....	42
10.1.1	The menu bar	43
10.1.2	The toolbar	44
10.1.3	Menu overview.....	44
11	Measurement settings	47
11.1	Warning messages.....	47
11.2	Enter measurement parameters with the LDS	48
11.2.1	Establish connection.....	48
11.2.2	Sensor parameters	48
11.2.3	Measurement window.....	49
11.2.4	The command line „Command“	50
11.2.5	Creating setups	51
11.2.6	Checking the beam position	52
11.3	Enter measurement parameters via the PLC	52
11.4	Determine exposure time with the help of the LDS	53
11.4.1	Preparation	53
11.4.2	Triggering a manual measurement	53
11.4.3	Setting the gain.....	54
11.5	Determine the exposure time via the PLC.....	55
12	Measuring	61
12.1	Measuring procedure	61
12.1.1	Measuring procedure power measurement	61
12.1.2	Measuring procedure focus measurement (untriggered)	62
12.1.3	Measuring procedure focus measurement (triggered)	63
12.1.4	Measuring procedure caustic measurement	64
12.1.5	Measuring procedure combined measurement	65
12.2	Timing diagrams	67
12.2.1	Timing diagram power measurement	67
12.2.2	Timing diagram focus measurement (untriggered)	68
12.2.3	Timing diagram focus measurement (triggered)	70
12.2.4	Timing diagram caustic measurement.....	72
12.2.5	Timing diagram combined measurement	73
12.3	Flow chart combined measurement	76
13	Display of a measurement in the web browser	78
14	Maintenance and service	80
14.1	Maintenance intervals.....	80
14.2	Cleaning.....	80
14.2.1	Cleaning the device surface	80
14.2.2	Cleaning the protective window	80
14.3	Spare parts	81
14.4	Maintenance of the protective window	82
14.4.1	Exchange of the protective window cartridge.....	83
14.4.2	Exchanging or cleaning of the protective window	84
15	Measures for the product disposal	85
16	Declaration of incorporation for partly completed machinery	86
17	Technical data	88
18	Dimensions	90

PRIMES - the company

PRIMES is a manufacturer of measuring devices for the analysis of laser beams. These devices are employed for the diagnostics of high-power lasers ranging from CO₂-, fiber- and solid-state lasers to diode lasers. A wavelength range from infrared to near UV is covered, offering a wide variety of measuring devices to determine the following beam parameters:

- Laser power
- Beam dimensions and position of an unfocused beam
- Beam dimensions and position of a focused beam
- Beam quality factor M²

Development, production and calibration of the measuring devices is performed at PRIMES. This guarantees optimum quality, excellent service, and a short reaction time, providing the basis for us to meet all of our customers' requirements quickly and reliably.



PRIMES GmbH
Max-Planck-Str. 2
64319 Pfungstadt
Germany

Tel +49 6157 9878-0
info@primes.de
www.primes.de

1 Basic safety notes

Intended use

The device has been designed exclusively for measurements in the beam of high-power lasers.

Use for any other purpose is considered as not intended and is strictly prohibited. Furthermore, intended use requires that all information, instructions, safety notes and warning messages in this operating manual are observed. The specifications given in chapter 17 „Technical data“ on page 88 apply. Any given limit values must be complied with.

If not used as intended, the device or the system in which the device is installed can be damaged or destroyed. In addition, there is an increased risk to health and life. Only use the device in such a way that there is no risk of injury.

This operating manual is an integral part of the device and must be kept in the immediate vicinity of the place of use, accessible to personnel at all times.

Every person who is responsible for the installation, start-up or operation of the device must have read and understood the operating manual and, in particular, the safety instructions.

If you still have questions after reading this operating manual, please contact PRIMES or your supplier for your own safety.

Observing applicable safety regulations

Observe the safety-relevant laws, guidelines, standards and regulations in the current editions published by the state, standardization organizations, professional associations, etc. In particular, observe the regulations on laser safety as well as machine safety and comply with their requirements.

Before commissioning, it must be ensured that the entire machine in which the device is installed meets these safety requirements. Otherwise, the commissioning of the device is prohibited.

Necessary safety measures

The device measures direct laser radiation, but does not emit any radiation itself. However, during the measurement the laser beam is directed at the device. This produces scattered or directed reflection of the laser beam (laser class 4). The reflected beam is usually not visible.

Protect yourself from direct and reflected laser radiation while working with the device by taking the following measures:

- Wear **safety goggles** adapted to the power, power density, laser wavelength and operating mode of the laser beam source in use.
- Wear suitable **protective clothing** or **protective gloves** if necessary.
- If possible, also protect yourself from direct laser radiation and scattered radiation by using separating protective devices that block or attenuate the radiation.
- If the device is moved from its aligned position, increased scattered or directed reflection of the laser beam occurs during measuring operation. Mount the device in such a way that it cannot be moved unintentionally, i.e. by bumping or pulling the cables.
- Install safety switches or emergency safety mechanisms that allow the laser to be switched off immediately.
- Use suitable beam guidance and beam absorber elements which do not emit any hazardous substances when irradiated.

Employing qualified personnel

The device may only be operated by qualified personnel. The qualified personnel must have been instructed in the installation and operation of the device and must have a basic understanding of working with high-power lasers, beam guiding systems and focusing units.

Conversions and modifications

The device may not be modified in terms of design or safety without the explicit consent of the manufacturer. The same applies to unauthorized opening, dismantling and repair. The removal of covers is only permitted within the scope of the intended use.

Liability disclaimer

Manufacturer and distributor exclude any liability for damages and injuries which are direct or indirect consequences of using the device not as intended or modifying the device or the associated software without authorization.

2 Symbols and conventions

Warning messages

The following icons and signal words indicate possible residual risks in the form of warnings:



DANGER

Means that death or serious physical injuries **will** occur if necessary safety precautions are not taken.



WARNING

Means that death or serious physical injuries **may** occur if necessary safety precautions are not taken.



CAUTION

Means that minor physical injury **may** occur if necessary safety precautions are not taken.

NOTICE

Means that property damage **may** occur if necessary safety precautions are not taken.

Product safety labels

The following icons are used on the device itself to indicate imperatives and possible dangers:



General warning sign



Read and understand the operating manual before using the device!



Labeling according to WEEE directive:

The device must not be disposed of with household waste, but in a separate WEEE collection in an environmentally friendly way.

Further icons and conventions in this operating manual



Here you will find useful information and helpful tips.



Indicates a single instruction.

If several of these instructions appear one below the other, the order in which they are executed is irrelevant or they represent alternative courses of action.

1.

A numbered list identifies a sequence of instructions that must be executed in the specified order.

2.

...



Indicates the result of an action to explain processes that take place in the background.



Indicates an observation prompt to draw attention to visible feedback from the device or the software.

Observation prompts make it easier to check whether an instruction was executed successfully. Often they also guide to the next instruction.



Points to a control element that is to be pressed/clicked.



Points to an element described in the text (for example an input field).

3 About this operating manual

This manual describes working with the FocusParameterMonitor FPM and both of its settings

- via a system using a PLC
- as well as with the LaserDiagnosticsSoftware LDS 2.98.

In this operating manual, the abbreviations FPM and LDS are used.

The FocusParameterMonitor FPM is intended to be used with a PLC for fully automated operation. Manual operation with a PC is not recommended.

However, since the FPM is designed for measuring short-term exposure and does not automatically adjust the exposure time, the appropriate exposure time must be determined for the various beam configurations. The LDS 2.98 can be used for setup.

The LDS 2.98 is available free of charge on the PRIMES website at:
<https://www.primes.de/de/support/downloads/software.html>.

4 Device description

4.1 Type overview



PRIMES offers further customer-specific variants. If you have one of these variants or require further information, please contact PRIMES.

The digits in the name indicate different types. These differ in their permitted full divergence angle as well as the imaging ratio (magnification).

- FPM 60 with a maximum divergence of 60 mrad and a 1:1 image
- FPM 100 with a maximum divergence of 100 mrad and a 5:1 image
- FPM 120 with a maximum divergence of 120 mrad and a 1.25:1 image
- FPM 160 with a maximum divergence of 160 mrad and a 3:1 image

The FPM is optionally equipped with a PROFIBUS or a PROFINET interface. For this purpose, the following connection layouts are available:

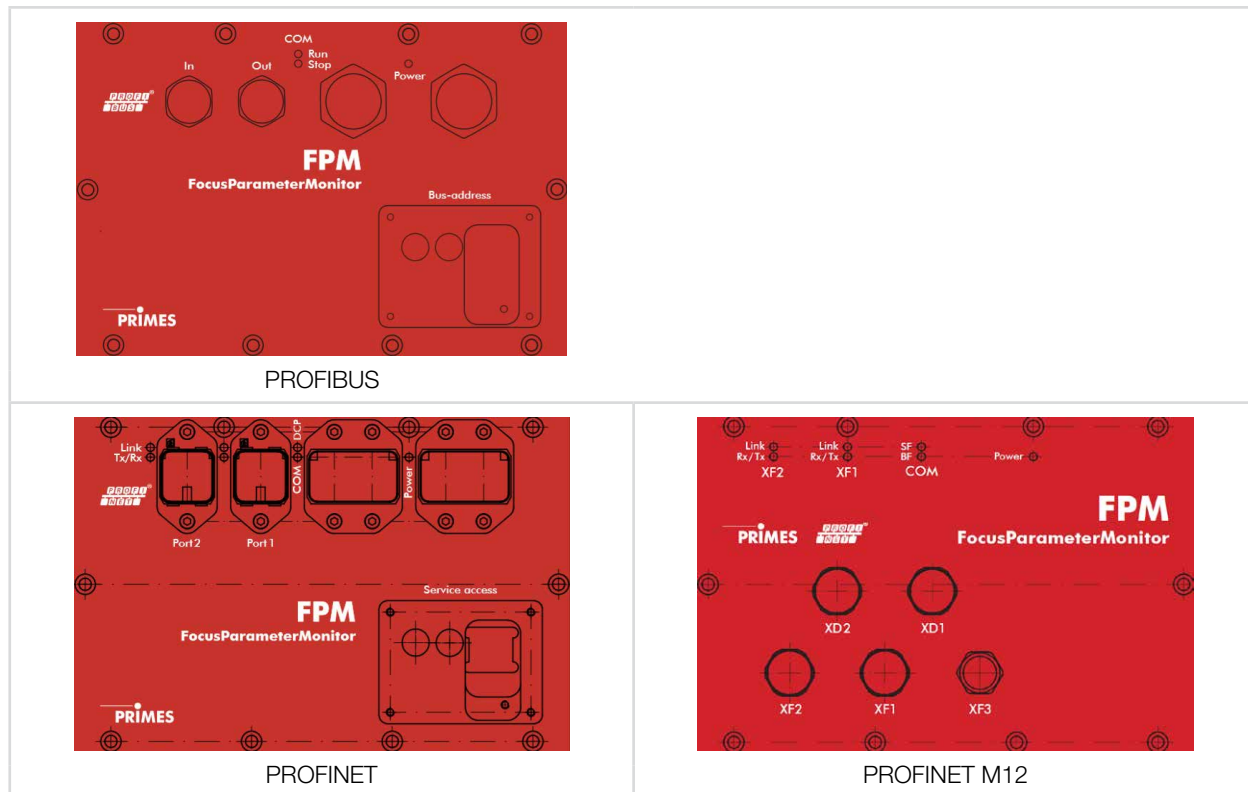

The following variants of the FPM are available:

- FPM 60 PROFIBUS
- FPM 60 PROFINET
- FPM 100 PROFIBUS
- FPM 100 PROFINET
- FPM 100-M12 PROFINET
- FPM 120 PROFINET
- FPM 120-M12 PROFINET
- FPM 160 PROFIBUS
- FPM 160 PROFINET
- FPM 160-M12 PROFINET

Devices with PROFINET and PROFIBUS connection layouts are available with an openly accessible or concealed Ethernet port. For PROFINET M12 devices, the Ethernet port XF3 is always freely accessible.

The device type is indicated on the identification plate.

4.2 Functional description

The FPM is designed for laser beam measurement. The beam quality is controlled by means of periodic measurements which ensure the process quality. The following parameters are measured:

- Laser power
- Power density distribution
- Beam position and beam geometry
- Caustic of laser beams

The FPM consists of 3 main components:

- Power measuring unit
- Beam analysis unit
- PROFIBUS or PROFINET interface

These components are included in a stable aluminium housing. An electrically operated shutter protects the beam entrance from pollution.

In addition, an exchangeable protective window is integrated. It is constantly surrounded by compressed air. The compressed air is required to create an overpressure in the housing, which prevents the penetration of dirt particles.

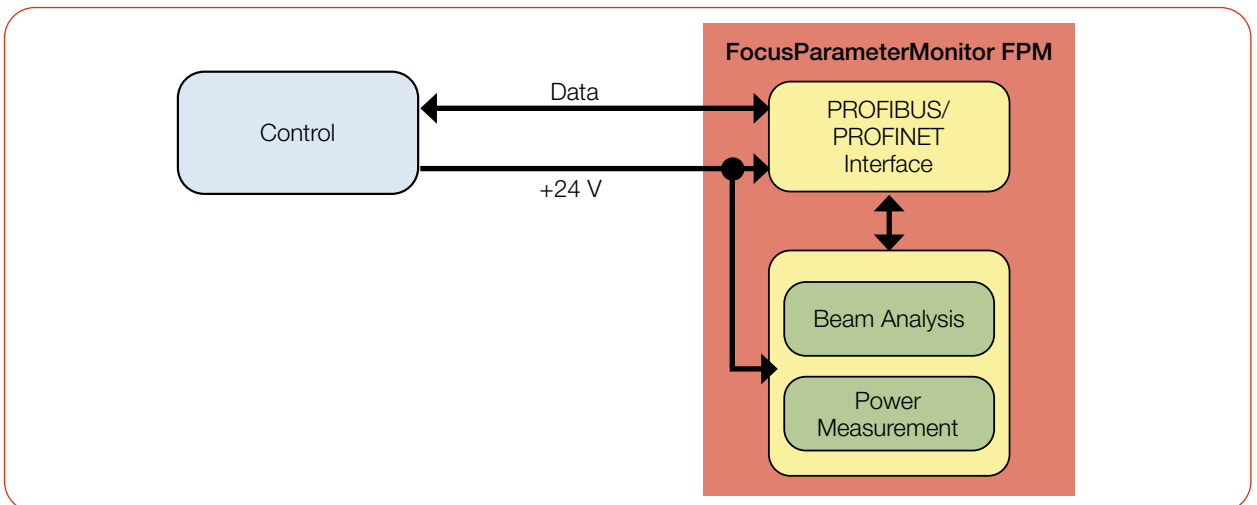

Fig. 4.1: Block diagram of the FPM

4.3 Measuring principle

The device determines the laser power in the power measuring unit according to the calorimetric principle. For this purpose, the absorber of the power measuring unit is irradiated with the laser for a defined time. Using the known absorber mass and the specific heat capacity of the absorber material, the introduced energy can be calculated by the measured temperature increase. The measured exposure time can then be used to calculate the power.

The beam geometry and the power density distribution are measured by the camera-based beam analysis unit using a CCD sensor. The measurement of beam parameters require an external z-axis.

The measurement data is transmitted to the system control via a PROFIBUS or PROFINET interface.

The beam coming from the laser is transmitted through the beam entrance to deflection mirror 1 and from there to a beam splitter.

The largest part of the beam enters an absorber which is part of the power measurement unit.

The attenuated beam reaches the beam analysis unit (CCD sensor) via deflecting mirror 2.

The power measuring unit is used to determine the power and the beam analysis unit is used to measure the beam position and geometry, the caustic and the power density distribution.

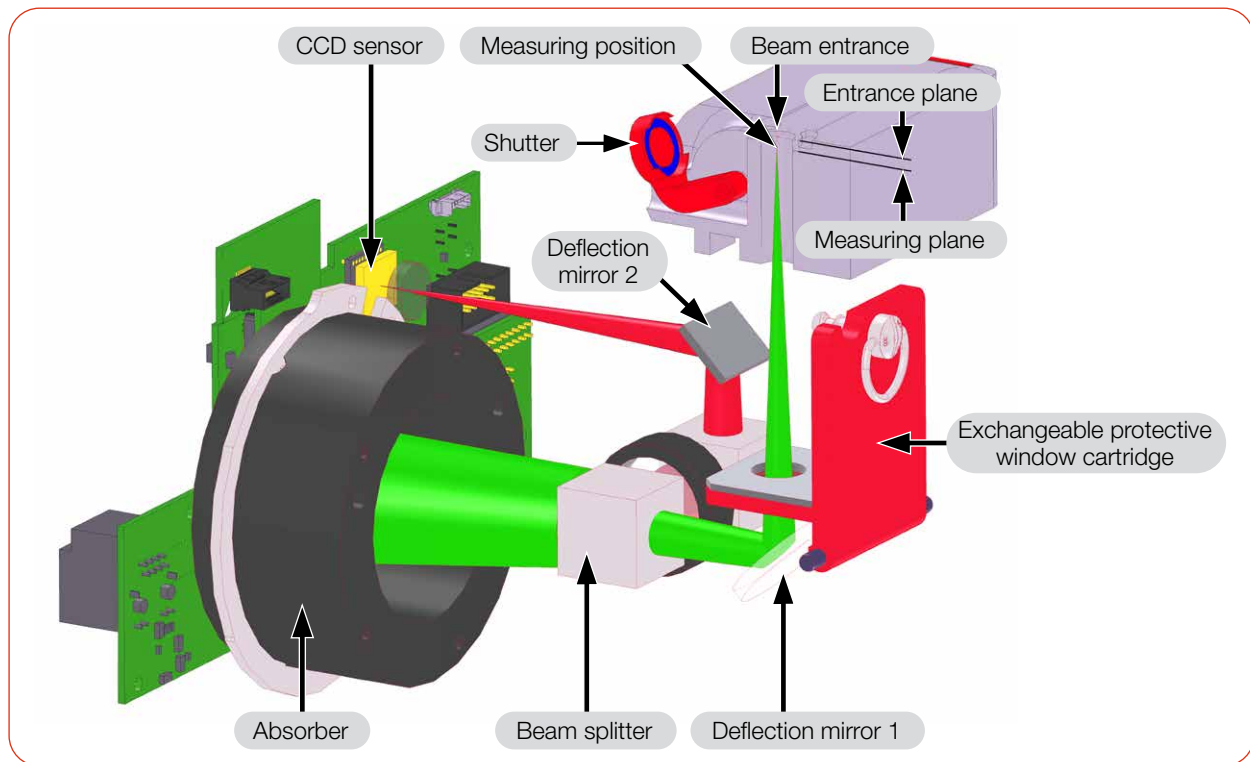
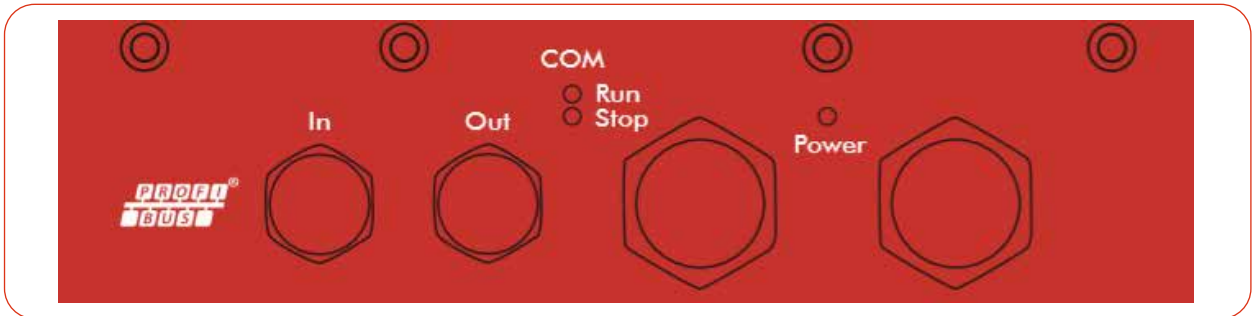

Fig. 4.2: Beam path inside FPM

i Please note that the measuring plane in the FPM is located below the entrance plane, depending on the imaging scale (magnification) and the configuration (see chapter 17 „Technical data“ on page 88).

4.4 Optical displays

4.4.1 FPM PROFIBUS



LED	Color	State	Meaning
Power	Green	On	Supply voltage applied.
COM Run	Green	On	Communication takes place on the bus.
COM Stop	Orange	On	There is a connection, but no data is exchanged.
	Orange	Blinks	The measuring device has no physical connection to the bus.

Tab. 4.1: LEDs and colors PROFIBUS

4.4.2 FPM PROFINET

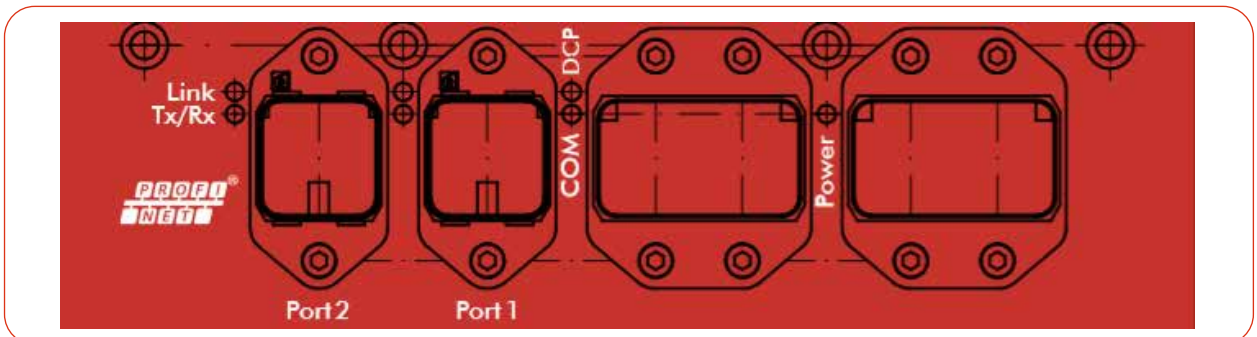

LED	Color	State	Meaning
Power	Green	On	Supply voltage applied.
COM	Green	On	Watchdog timeout or „Channel, generic or extended diagnostics present“ or system error.
	Green	Blinks	DCP signal service is triggered via the bus.
	Red	On	No configuration or slow physical connection or no physical connection.
	Red	Blinks	No data exchange.
Link (Port 1 and Port 2)	Green	On	The device has a connection to the Ethernet.
Tx/Rx (Port 1 and Port 2)	Yellow	Flickers	The device sends/receives Ethernet frames.

Tab. 4.2: LEDs and colors PROFINET

4.4.3 FPM PROFINET M12

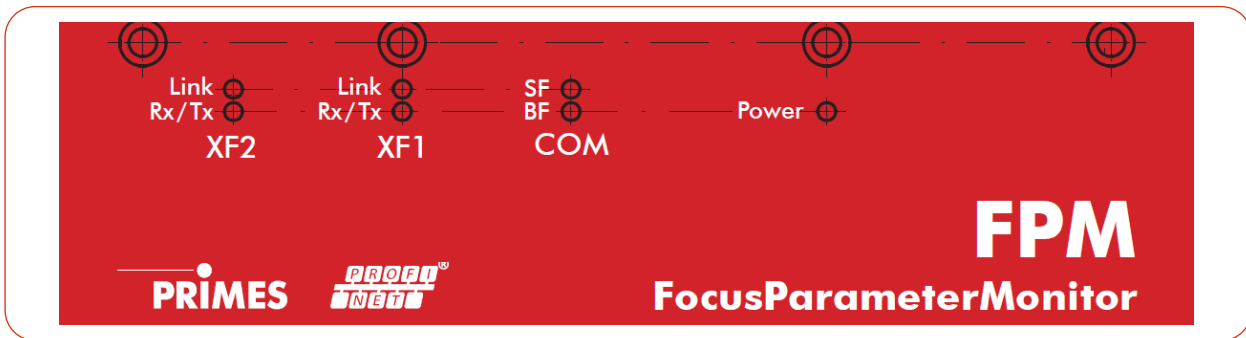

LED	Color	State	Meaning
Power	Green	On	Supply voltage applied.
COM	Green	On	Watchdog timeout or „Channel, generic or extended diagnostics present“ or system error.
		Off	Error-free fieldbus communication (Power Led lights green).
	Green	Blinks	DCP signal service is triggered via the bus.
	Red	On	No configuration or slow physical connection or no physical connection.
	Red	Blinks	No data exchange.
Link (XF 1 and XF 2)	Green	On	The device has a connection to the Ethernet.
Rx/Tx (XF 1 and XF 2)	Yellow	Flickers	The device sends/receives Ethernet frames.

Tab. 4.3: LEDs and colors PROFINET M12

4.5 Scope of delivery and optional accessories

The scope of delivery includes:

- FPM
- PRIMES USB flash drive
- Operating manual

The following accessories are optional:

- Transport and storage case

5 Transport and storage

NOTICE

Damage/destruction of the device

Hard impacts or dropping can damage the optical components.

- ▶ Handle the measuring device carefully during transport and installation.

6 Mounting



DANGER

Serious eye or skin injury due to laser radiation

An improper installation by unqualified personnel can lead to material damage or even personal injury.

- ▶ Have the device installed by qualified personnel only. Qualified personnel must have basic knowledge about working with high-power lasers, beam delivery systems and focusing units.

6.1 Conditions at the installation site

- The device must not be operated in a condensing atmosphere.
- The ambient air must be free of gases and aerosols that interfere with the laser radiation (e.g. organic solvents, cigarette smoke, sulfur hexafluoride).
- Protect the device from splashes of water and dust.
- Operate the device in closed rooms only.

6.2 Installation in the laser system

The FPM is intended for the installation into a laser system. Therefore neither constructive nor safety related modifications may be made to the FPM unless we have given our explicit written consent. In case of any modifications, we do not accept any liability for resulting damages.

6.2.1 Prepare mounting

NOTICE

Damage/destruction of the device

Too little space in front of the shutter can damage the device.

- ▶ Make sure that there is enough free space to open the shutter.

1. Switch off the laser beam.
2. Ensure that moving parts, e.g. robot arms, etc. are at a standstill and that they cannot be set in motion unintentionally.
3. Check the space available before installing the device, especially the required space for the connection cables and hoses/shutter.

6.2.2 Possible mounting positions

The FPM can be mounted both horizontally and vertically. Due to the danger of contamination we recommend a vertical mounting with a horizontal beam incidence. The plug connections should point downwards and unused sockets should be covered with the caps supplied.

6.2.3 Align the device



DANGER

Serious eye or skin injury due to laser radiation

If the device is moved from its aligned position, increased scattered or directed reflection of the laser beam occurs during measuring operation (laser class 4).

- ▶ Mount the device so that it cannot be moved by an unintended push or a pull on cables.

The device must be aligned to the laser beam. The laser beam must hit the entrance aperture centrally and perpendicular. The specifications given in chapter 17 „Technical data“ on page 88 must be observed.

Depending on the variant, the measurement plane can be located up to 25 mm below the entrance plane.

The marking on the shutter can be used as an alignment aid. Align the device using the pilot beam with the shutter closed.

6.2.4 Mount the device

NOTICE

Damage/destruction of the device

Screws which are too long can damage the mounting threads.

- ▶ When choosing the mounting screws, please ensure that the maximum extension into the device does not exceed 12 mm.

- **Stability:** Mount the measuring device in a stable condition so that uncontrolled movement of the device relative to the beam axis is prevented, thus reducing the hazard from scattered radiation.
- **Mounting space:** Please note that the shutter is opened or closed during operation of the FPM. Complete opening of the shutter must be ensured. After mounting the device, check that the shutter cannot collide with the laser system.
Ensure that there is no danger to operating personnel due to clamping/crushing.

In the base plate of the housing as well as in the side wall there are 4 mounting threads M6 x 12 mm for the fixture on a customer specific mounting (see Fig. 6.1 and Fig. 6.2).

Mount the housing with 4 screws M6. PRIMES recommends screws of the strength class 8.8 and a tightening torque of 35 Nm.

There are also 2 slip fit bores $\varnothing 6$ H7x10 each in the base and in the side panel for precise and reproducible alignment of the device.

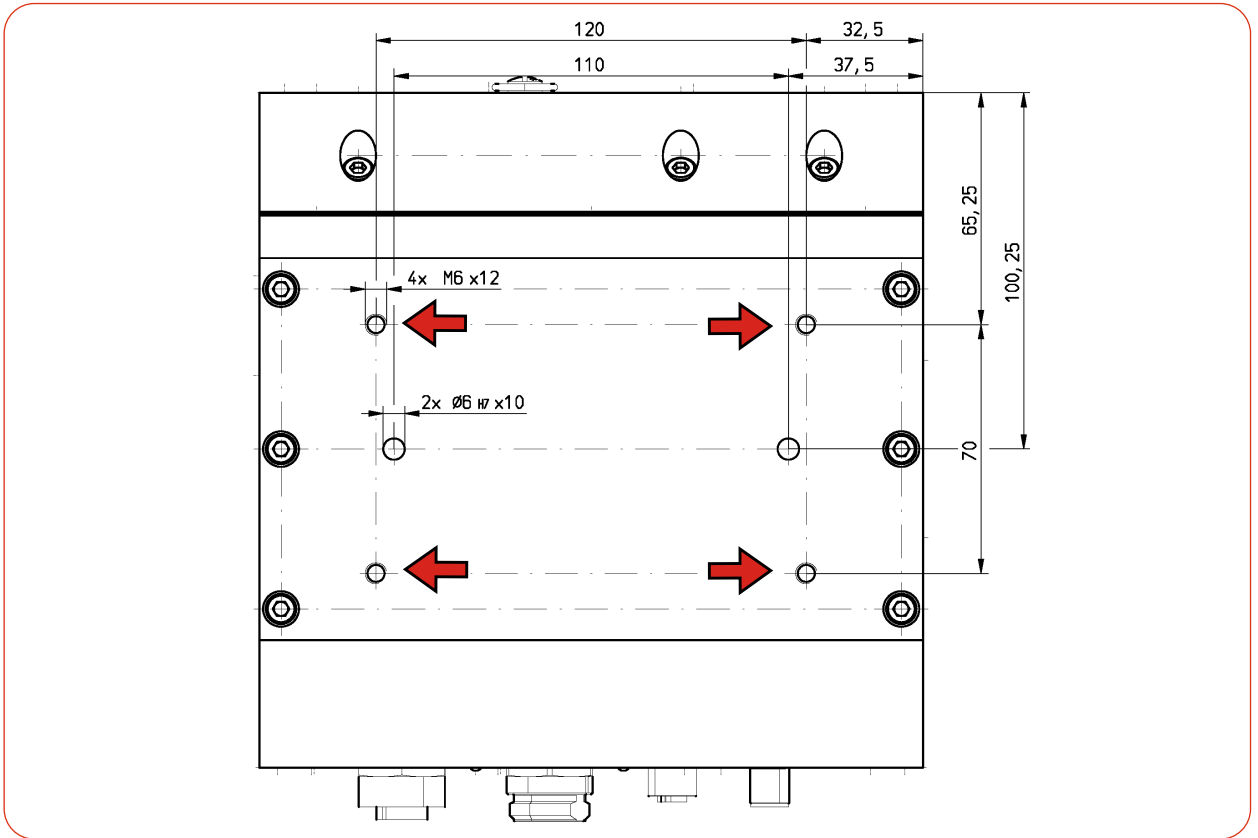

Fig. 6.1: Mounting threads and slip fit bores in the base plate

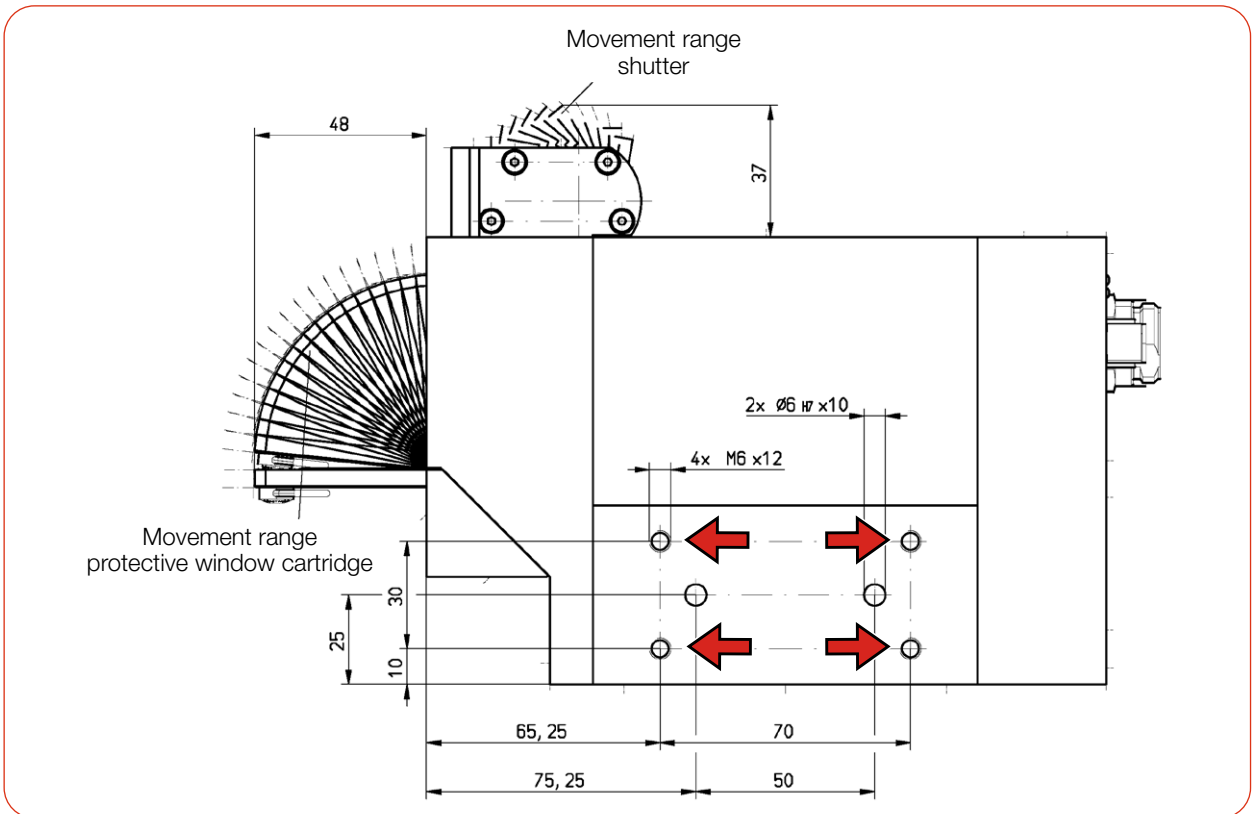

Fig. 6.2: Mounting threads and slip fit bores in the side wall

6.3 Removal from the laser system

1. Switch off the laser beam.
2. Ensure that moving parts, e.g. robot arms, etc. are at a standstill and that they cannot be set in motion unintentionally.
3. Check that the shutter is closed.
4. Disconnect the device from the power supply.
5. Turn off the compressed air supply.
6. Push down the release ring of the compressed air connector with two fingers of one hand and pull out the hose with the other hand.
7. Disconnect all connections.
8. Unscrew the fastening screws.
9. Remove the device from the laser system.

7 Connectors

7.1 FPM PROFIBUS

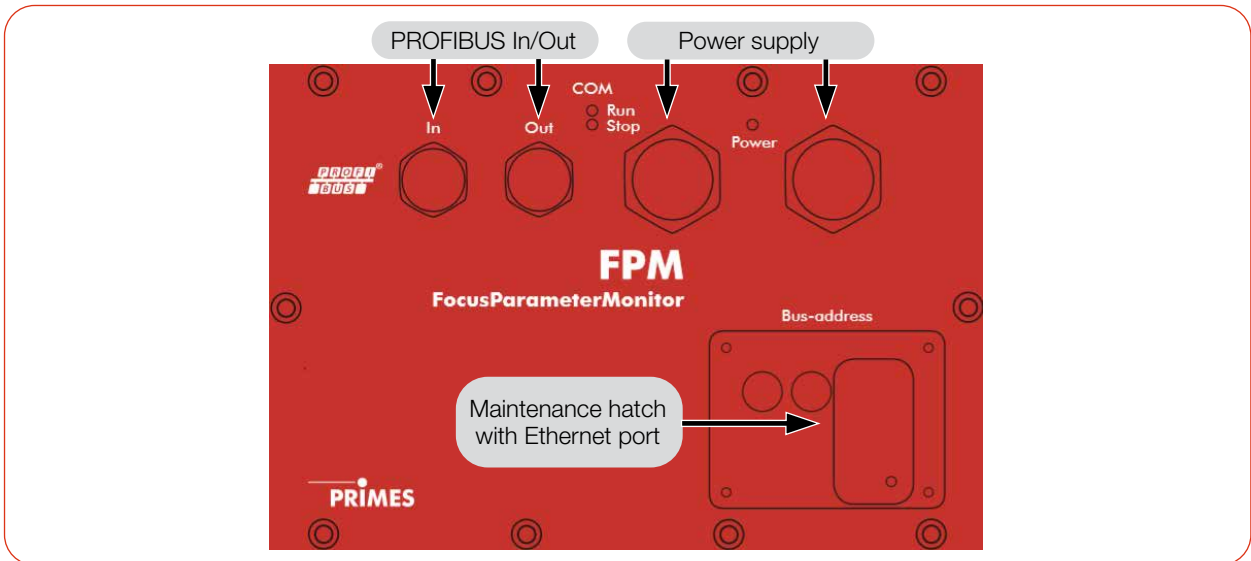

Fig. 7.1: Connectors FPM PROFIBUS

7.1.1 Interface description PROFIBUS

Both the bus interface and the power supply are duplicated so that the FPM can be inserted into a line structure. There are 5 interfaces in total:

- 2 x PROFIBUS ports
- 2 x 24 V power supplies (24 V ± 5 %, max. 500 mA current consumption)
- 1 x Ethernet port

The data is stored in registers in Motorola format. This means that high bytes are stored first and the lower bytes follow on the next registers.

PROFIBUS (In/Out)

The plug or socket for PROFIBUS is a 5-pole, B-coded M12 connector.

Pin assignment plug (top view mating side)	Pin	Function
	1	Not connected
	2	Signal A
	3	Not connected
	4	Signal B
	5	Not connected

Pin assignment socket (top view mating side)	Pin	Function
	1	+5 V
	2	Signal A
	3	ISOGND
	4	Signal B
	5	Not connected

Tab. 7.1: Connectors PROFIBUS

Power supply (Power)

Power is supplied via 7/8" connectors.
The 2 connectors are internally connected 1:1.

Pin assignment (top view mating side)	Pin	Function
<p>Plug Socket</p>	1	GND actuator
	2	GND sensor
	3	FE (functional earth)
	4	Sensor supply 24 V
	5	Actuator supply 24 V

Tab. 7.2: Connectors power supply

Ethernet

The Ethernet port is either hidden under the maintenance cover (Bus-address) or in a maintenance hatch with a freely accessible Ethernet port. The Ethernet port is an RJ45 connector.

7.1.2 Set PROFIBUS address

1. Remove the 4 screws from the maintenance cover.
2. Use rotary switches A and B to set the desired bus address. The arrowhead of the rotary switch must point to the corresponding number.
3. Note that the address has two digits. Use switch A to set the first digit (tens), use switch B to set the second digit (ones).
The PROFIBUS address can be set from 1 to 99. The address 17 is set at the factory.
4. Put the cover back in place and screw it on.

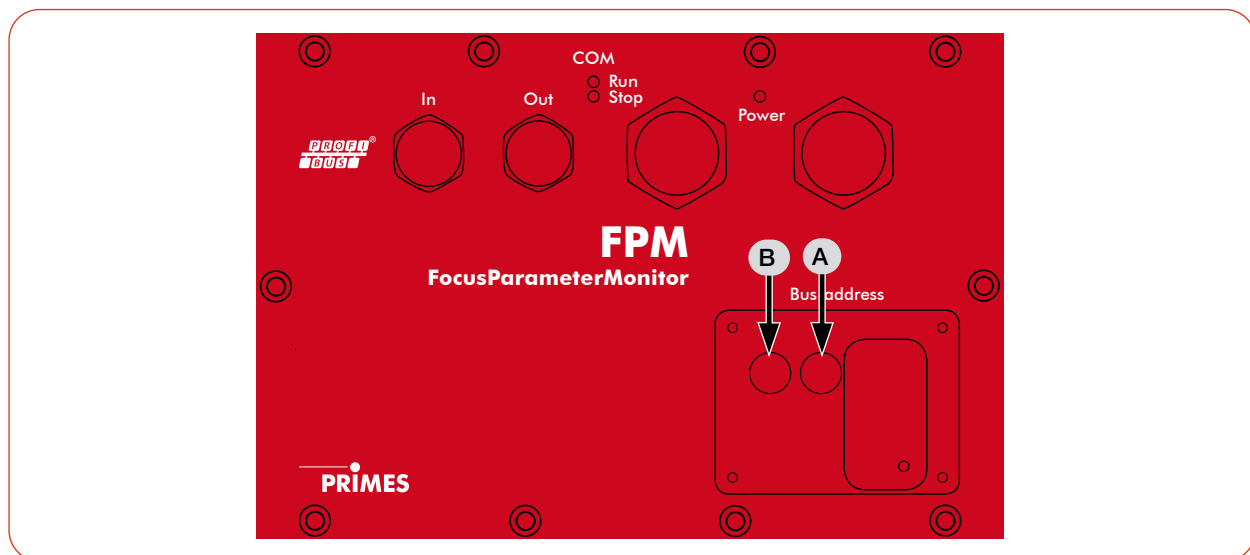

Fig. 7.2: Rotary switch under the maintenance cover

7.1.3 Device master file (GSD file)

The GSD file for the FPM without a caustic option and with a PROFIBUS interface has the name:
PRI_0307.GSD

It is located on the supplied PRIMES USB flash drive.

Fig. 7.3 on page 21 shows the integration of the GSD file under Step 7.

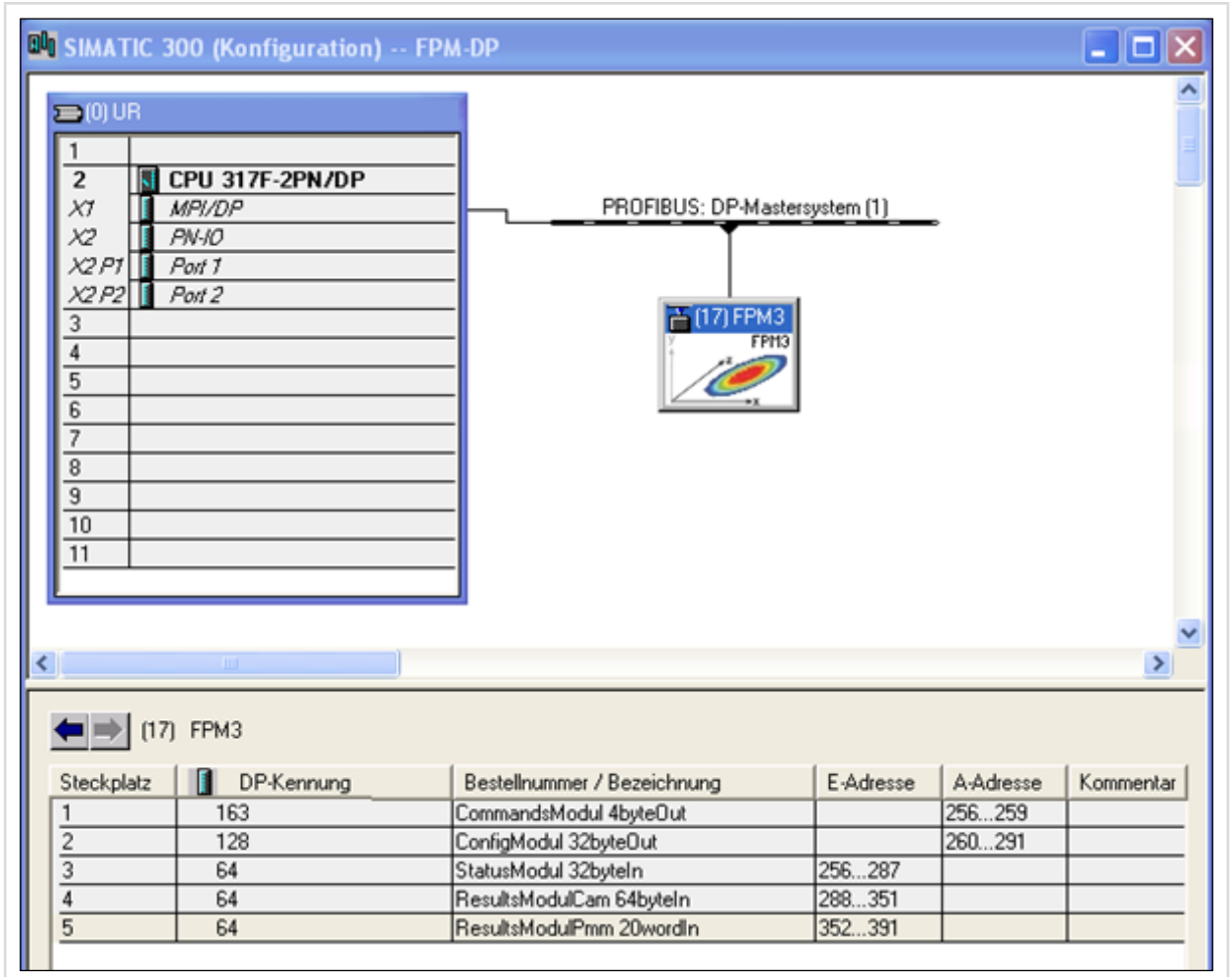

Fig. 7.3: Integration of the GSD file under Step 7

7.2 FPM PROFINET

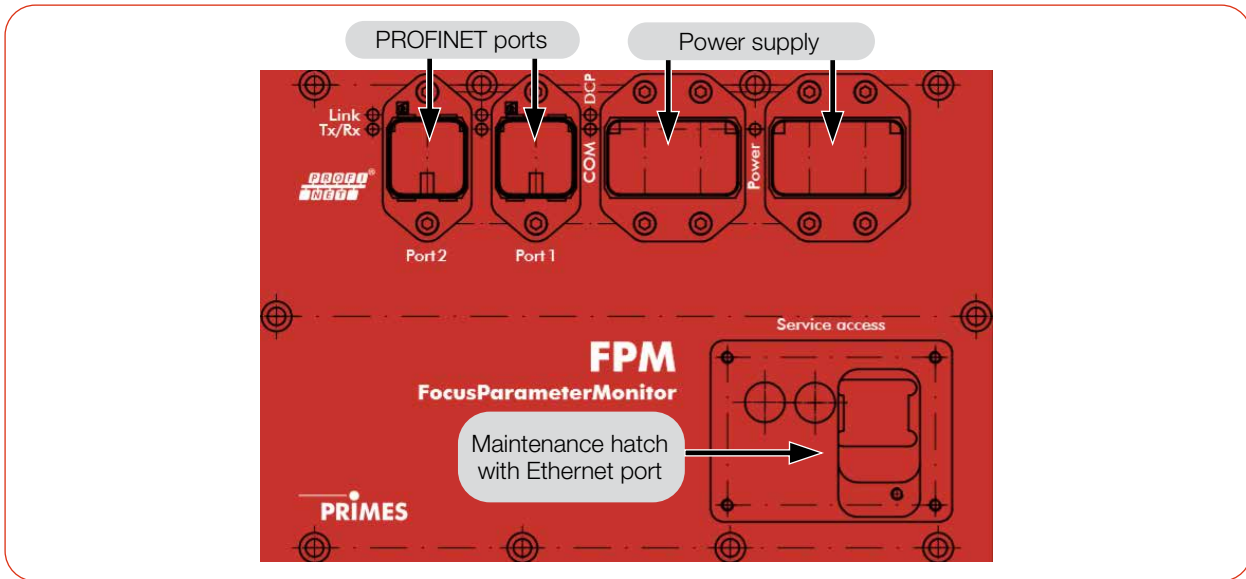

Fig. 7.4: Connectors FPM PROFINET

7.2.1 Interface description PROFINET

Both the bus interface and the power supply are duplicated so that the FPM can be inserted into a line structure. There are 5 interfaces in total:

- 2 x PROFINET ports
- 2 x 24 V power supplies (24 V ± 5 %, max. 500 mA current consumption)
- 1 x Ethernet port

The data are stored in registers in Motorola format. This means that high bytes are stored first and the lower bytes follow on the next registers.

PROFINET (Port 1/Port 2)

The PROFINET connectors are AIDA-compatible RJ45 connectors. The 2 RJ45 sockets are internally connected via an integrated switch.

Power supply (Power)

Power is supplied via AIDA-compatible connectors. The 2 connectors are internally connected 1:1.

The FPM has a current requirement of less than 500 mA, drawn from the sensor supply.

Pin assignment (top view mating side)	Pin	Function
	1	Sensor power supply 24 V
	2	GND sensor
	3	Actuator power supply 24 V
	4	GND actuator
	5	FE (functional earth)

Tab. 7.3: Connector power supply

Ethernet

The Ethernet port is either hidden under the maintenance cover (bus address) or in a maintenance hatch with a freely accessible Ethernet port.

The Ethernet port is an RJ45 connector.

7.2.2 Device master file (GSDML file)

The GSDML file for the FPM with caustic option and with a PROFINET interface has the name:

GSDML-V2.2-PRIMES-FPM-PN-CU-AIO-20151022.xml

It is located on the supplied PRIMES USB flash drive.

Fig. 7.5 on page 23 shows the integration of the GSDML file under Step 7.

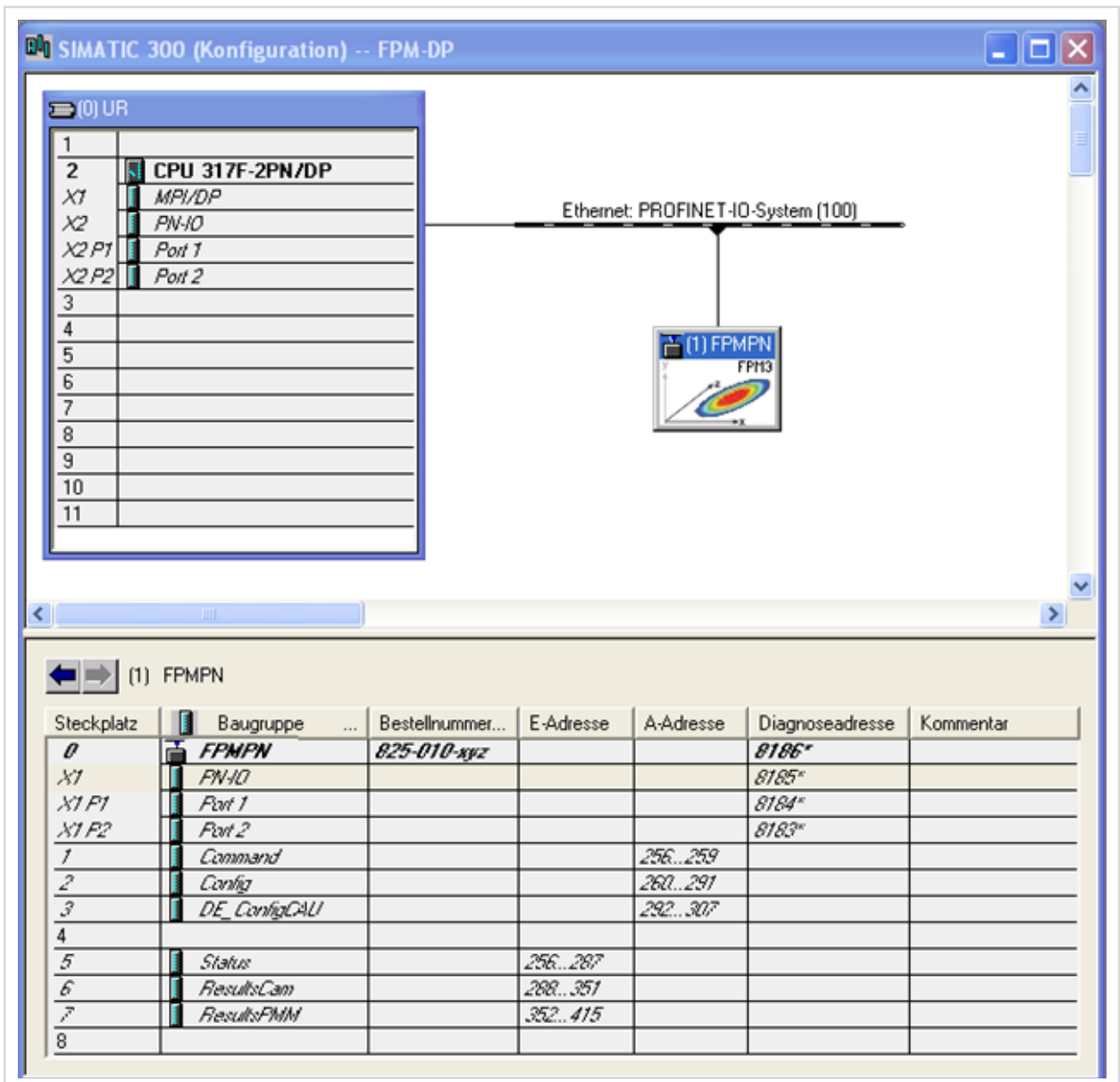

Fig. 7.5: Integration of the GSDML file under Step 7

7.3 FPM PROFINET M12

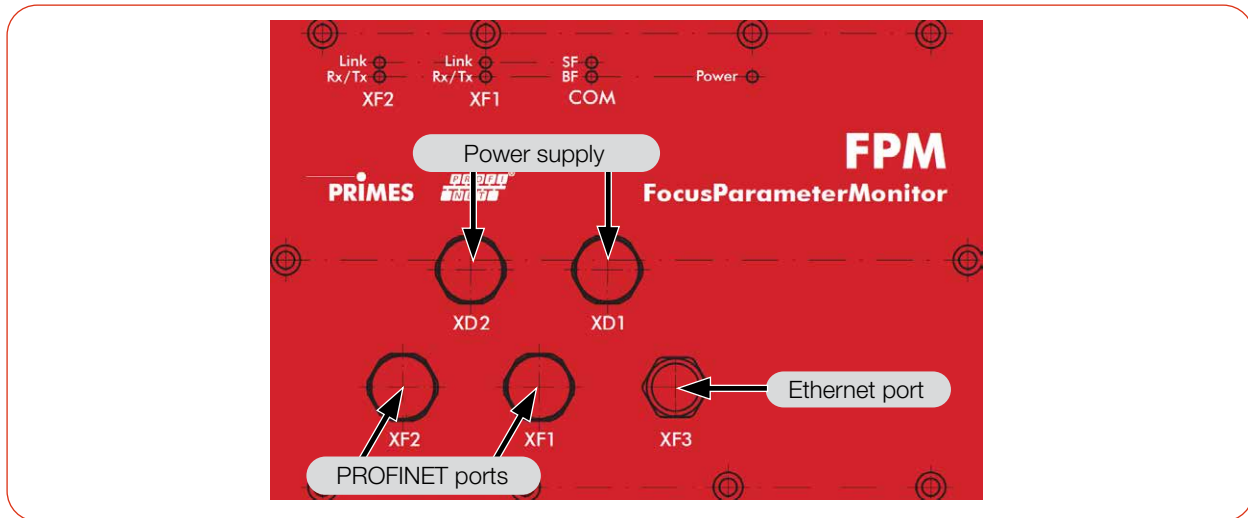

Fig. 7.6: Connectors FPM PROFINET M12

7.3.1 Interface description PROFINET M12

Both the bus interface and the power supply are duplicated so that the FPM can be inserted into a line structure. There are 5 interfaces in total:

- 2 x PROFINET ports
- 2 x 24 V power supplies (24 V ± 5 %, max. 500 mA current consumption)
- 1 x Ethernet port

The data are stored in registers in Motorola format. This means that high bytes are stored first and the lower bytes follow on the next registers.

PROFINET (XF1/XF2)

The connectors for the PROFINET M12 data connection are 4-pin, D-coded M12 SPEEDCON connectors. The 2 connectors are internally connected via an integrated switch.

Pin assignment (top view mating side)	Pin	Function
	1	Transmission data +
	2	Transmission data -
	3	Receive data +
	4	Receive data -
Sockets designation: Phoenix-Contact SACC-E-FSD-4CON-M16/0,5 SCO		

Tab. 7.4: Connector data

Power supply (XD1/XD2)

The connectors for the PROFINET M12 power supply are 5-pin, L-coded M12 connectors. They are internally through-connected 1:1.

The plug is used for feeding, the socket for looping through the supply voltage

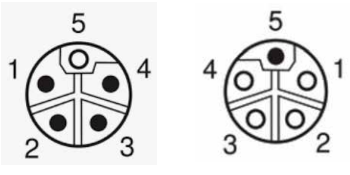
Pin assignment (top view mating side)	Pin	Function
 <p style="text-align: center;">Plug Socket</p>	1	Sensor power supply 24 V
	2	GND actuator
	3	GND sensor
	4	Actuator power supply 24 V
	5	FE (functional earth)

Tab. 7.5: Connectors power supply

Ethernet (XP3)

The connector for the PROFINET M12 Ethernet port is an 8-pin, X-coded M12 SPEEDCON connector.

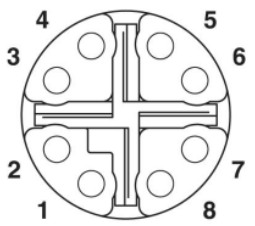
Pin assignment (top view mating side)	Pin	Function
	1	TX+
	2	TX-
	3	RX+
	4	RX-
	5	Not connected
	6	Not connected
	7	Not connected
	8	Not connected

Sockets designation: Phoenix-Contact 1404548 VS-BH-M12FSX-10G-RJ45-90

Suitable cable: Phoenix Contact 105477; Patch cable CAT6A M12 auf RJ45; VS-M12MSS-IP20-94F/ 5,0/10G (1440627).

Tab. 7.6: Ethernet port

7.3.2 Device master file (GSDML file)

The GSDML file for the FPM with caustic option and with PROFINET M12 interface has the name:

GSDML-V2.42-FPM-PN-CU-20220922.xml

It is located on the supplied PRIMES USB flash drive.

Fig. 7.7 on page 26 shows the integration of the GSDML file under Step 7.

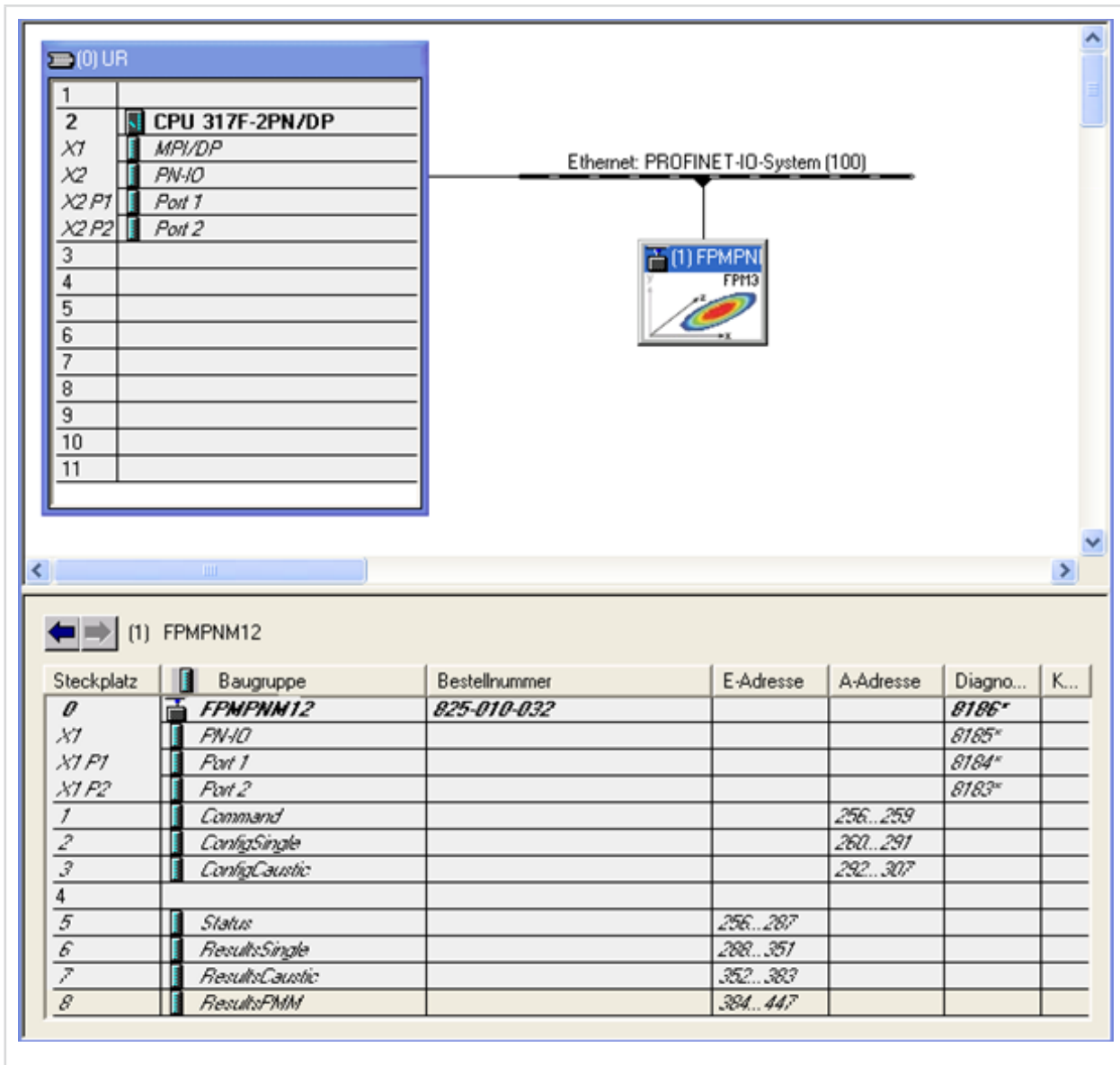

Fig. 7.7: Integration of the GSDML file under Step 7

7.4 Locking device for interlock

If the device is mounted in a welding gun, for example, the contact pressure establishes an electrical connection between the contact piece and the lower part.

This can be used to monitor the device through an interlock connection.

7.5 Compressed air connection

NOTICE

Risk of damage to optical components

Contaminated compressed air can cause permanent damage to the optical components of the measuring device

- ▶ The compressed air must comply with purity class ISO 8573-1:2010 [1:4:2].

Connecting the compressed air hose

- ▶ Push the hose into the plug-in connection as far as possible.

Disconnecting the compressed air hose

- ▶ Press down the blue release ring of the connector with one hand and pull out the hose with the other hand.

Data	Value
Outer diameter of the hose (Polyurethan)	4 mm
Flow rate (typical)	10 - 15 l/min
Maximum allowable pressure	2 bar
Purity classes	ISO 8573-1:2010 [1:4:2]



When the shutter is closed the flow rate can be reduced to 1-2 l/min in order to save resources.

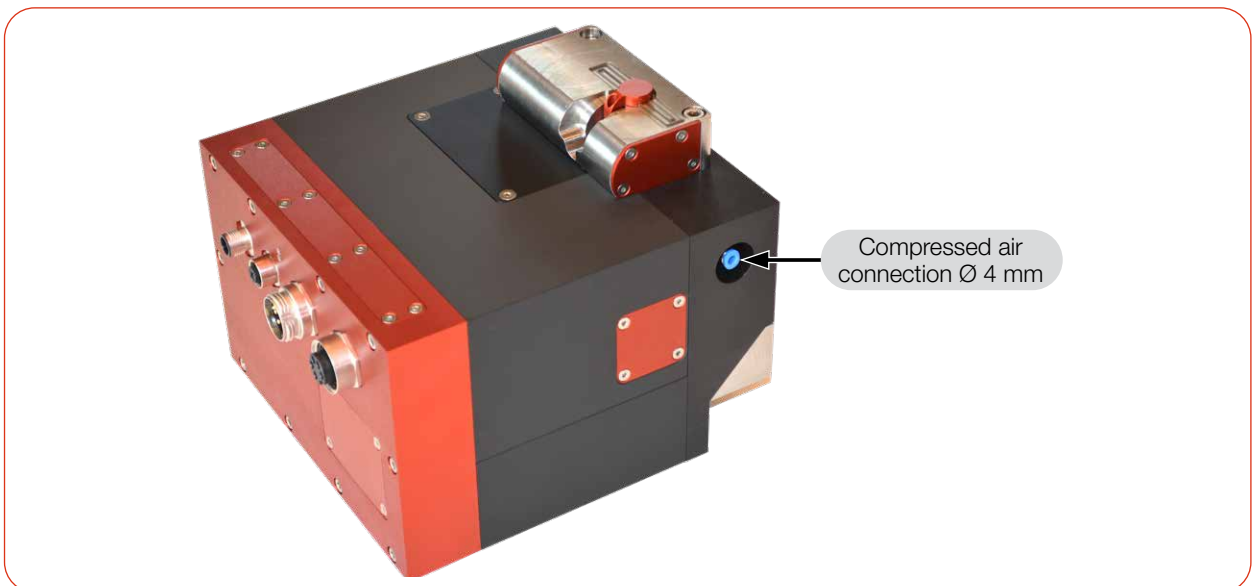

Fig. 7.8: Device view, compressed air connection

8 PROFIBUS/PROFINET parameter set

The data that the FPM exchanges with the higher-level controller via the fieldbus can be divided into input and output data as well as information for detecting errors:

In the registers the data is stored in the following format:

Fieldbus	Format
PROFINET, PROFIBUS	Motorola format, Big Endian

Tab. 8.1: Transmission formats

For the input data, a distinction is made between:

- FPM PROFIBUS
- FPM PROFINET
- FPM PROFINET M12



PRIMES offers further customer-specific variants. If you have one of these variants or require further information, please contact PRIMES.

FPM PROFIBUS

Refers to the GSD file from chapter 7.1.3 „Device master file (GSD file)“ on page 21.

In this GSD file the used input addresses are divided into 3 blocks:

- [StatusModul \(256 - 287\): 32 Byte](#)
- [ResultsModulCam \(288 - 351\): 64 Byte](#)
- [ResultsModulFPM \(352 - 391\): 64 Byte](#)

FPM PROFINET

Refers to the GSDML file from chapter 7.2.2 „Device master file (GSDML file)“ on page 23.

In this GSDML file the used input addresses are divided into 3 blocks:

- [Status \(256 - 287\): 32 Byte](#)
- [ResultsCam \(288 - 351\): 64 Byte](#)
- [ResultsFPM \(352 - 415\): 64 Byte](#)

FPM PROFINET M12

Refers to the GSDML file from chapter 7.3.2 „Device master file (GSDML file)“ on page 26.

In this GSDML file the used input addresses are divided into 4 blocks:

- [Status \(256 - 287\): 32 Byte](#)
- [ResultsSingle \(288 - 351\): 64 Byte](#)
- [ResultsCaustic \(352 - 383\): 32 Byte](#)
- [ResultsFPM \(384 - 447\): 64 Byte](#)

8.1 Inputs

In	FPM PROFIBUS	Address	FPM PROFINET	Unit/refresh rate	Length	Type	Sign
Version (read only)	256		256	Device/Software revision	fix	2 Byte	WORD
Constants (read only)	258		258	Maximal capacity		4 Byte	DWORD
	262		262	Minimal energy		4 Byte	DWORD
	266		266	Minimal irradiation time		2 Byte	WORD
	268		268	Maximal irradiation time		2 Byte	WORD
	270		270	Maximal power		2 Byte	WORD
	272		272	Minimal absorber temperature		2 Byte	WORD
	274		274	Maximal absorber temperature		2 Byte	WORD
	276		276	Pulse duration measurement available		2 Byte	WORD
	278		278	Device type		2 Byte	WORD
	280		280	Release		2 Byte	WORD

In	FPM PROFINET M12		Unit/refresh rate	Length	Type	Sign
	Address					
Version (read only)		256	Serial number	fix	4 Byte	DWORD
Constants (read only)		260	Firmware revision	fix	2 Byte	WORD
		260	Major revision	fix	1 Byte	BYTE
		261	Minor revision	fix	1 Byte	BYTE
		264	Max. power	W/fix	2 Byte	WORD
		266	Max. absorber temperature	°C /fix	2 Byte	WORD
		268	Max. measuring window x	µm /fix	2 Byte	WORD
		270	Max. measuring window y	µm /fix	2 Byte	WORD
		272	Pixel size	µm /fix	2 Byte	WORD
	274 - 281		Reserve	fix	8 Byte	

In	FPM PROFIBUS	FPM PROFINET	FPM PROFINET M12	Unit/refresh rate	Length	Type	Sign
	Address						
Status; caustic measurement (read only)	282.0	282.0	282.0	Ready for measurement	> 1Hz	1 Byte	BOOL
	282.1	282.1	282.1	Measurement running	> 1Hz		BOOL
	282.2	282.2	282.2	Measurement finished	> 1Hz		BOOL
	282.3	282.3	282.3	Measurement failure	> 1Hz		BOOL
	282.4	282.4	282.4	Idle	> 1Hz		BOOL
	282.5	282.5	282.5	Irradiation failure	> 1Hz		BOOL
	282.6	282.6	282.6	Start acknowledge	> 1Hz		BOOL
	282.7	282.7	282.7	Setup params read	> 1Hz	BOOL	
	283.0	283.0	283.0	Caustic measurement running	> 1Hz	1 Byte	BOOL
	283.1	283.1	283.1	Caustic measurement finished	> 1Hz		BOOL
	283.2	283.2	283.2	Caustic measurement failure	> 1Hz		BOOL
	283.3	283.3	283.3				BOOL
	283.4	283.4	283.4				BOOL
	283.5	283.5	283.5				BOOL
283.6	283.6	283.6			BOOL		
283.7	283.7	283.7			BOOL		
Status; power measurement	284.0	284.0	284.0	Ready		1 Byte	BOOL
	284.1	284.1	284.1	Running			BOOL
	284.2	284.2	284.2	Finished			BOOL
	284.3	284.3	284.3	Too hot			BOOL
	284.4	284.4	284.4	Idle			BOOL
	284.5	284.5	284.5	Irradiation failure			BOOL
	284.6	284.6	284.6	Start acknowledge			BOOL
284.7	284.7	284.7	Shutter acknowledge		BOOL		
Status; shutter	285.0	285.0	285.0	Shutter is open		1 Byte	BOOL
	285.1	285.1	285.1	Shutter is closed			BOOL
	285.2	285.2	285.2	Shutter is moving			BOOL
	285.3	285.3	285.3	Shutter timeout			BOOL
	285.4	285.4	285.4	Error shutter angle sensor			BOOL
	285.5	285.5	285.5				BOOL
	285.6	285.6	285.6				BOOL
285.7	285.7	285.7			BOOL		
Status; reserve	286	286	286		2 Byte	WORD	

In	FPM PROFIBUS	FPM PROFINET	FPM PROFINET M12	Unit/ refresh rate	Length	Type	Sign	
	Address							
Warnings and errors (read only)	288.0	288.0	288.0	Group warning: general warning	1 Byte	BOOL		
	288.1	288.1	288.1			BOOL		
	288.2	288.2	288.2	Group warning: single measurement warning		BOOL		
	288.3	288.3	288.3	Group warning: caustic measurement warning		BOOL		
	288.4	288.4	288.4	Group error: hardware error		BOOL		
	288.5	288.5	288.5	Group error: parameter error		BOOL		
	288.6	288.6	288.6	Group error: single measurement error		BOOL		
	288.7	288.7	288.7	Group error: caustic measurement error		BOOL		
	289	289	289		1 Byte	BYTE		
	290	290	290	Identifier for general warnings	per measuring cycle	2 Byte	WORD	
	292	292	292	Identifier for single measurement warnings	per measuring cycle	2 Byte	WORD	
	294	294	294	Identifier for caustic measurement warnings	per measuring cycle	2 Byte	WORD	
	296	296	296	Identifier for hardware errors	per measuring cycle	2 Byte	WORD	
	298	298	298	Identifier for parameter errors	per measuring cycle	2 Byte	WORD	
	300	300	300	Identifier for single measurement errors	per measuring cycle	2 Byte	WORD	
302	302	302	Identifier for caustic measurement errors	per measuring cycle	2 Byte	WORD		
Variable; single plane (read only)	304	304	304	Beam radius combined	m ^{*E-7} /measuring cycle	2 Byte	WORD	
	306	306	306	Beam radius in x	m ^{*E-7} /measuring cycle	2 Byte	WORD	
	308	308	308	Beam radius in y	m ^{*E-7} /measuring cycle	2 Byte	WORD	
	310	310	310	Beam position in x	µm/measuring cycle	2 Byte	WORD	
	312	312	312	Beam position in y	µm/measuring cycle	2 Byte	WORD	
	314	314	314	Angle x	°*E-2/measuring cycle	2 Byte	WORD	+/-
	316	316	316	Beam volume	ADC-Counts	4 Byte	DWORD	
	320	320	320	Peak Intensity	kW/cm ² /measuring cycle	4 Byte	DWORD	
	324	324	324	Level indicator: maximum of raw data	per measuring cycle	2 Byte	WORD	
	326	326	326	% of beam overdriven (i.e. raw data == 4095)	%/measuring cycle	1 Byte	BYTE	
	327	327	327	Fill factor	%/measuring cycle	1 Byte	BYTE	
328	328	328	ROI window position x	µm/measuring cycle	2 Byte	WORD		

In	FPM PROFIBUS	FPM PROFINET	FPM PROFINET M12	Address	Unit/ refresh rate	Length	Type	Sign
	Address							
Variable; single plane (read only)	330	330	330	ROI window position y	$\mu\text{m}/$ measuring cycle	2 Byte	WORD	
	332	332	332	ROI window size x	$\mu\text{m}/$ measuring cycle	2 Byte	WORD	
	334	334	334	ROI window size y	$\mu\text{m}/$ measuring cycle	2 Byte	WORD	
	336	336	336	ROI resolution x	Pixel	2 Byte	WORD	
	338	338	338	ROI resolution y	Pixel	2 Byte	WORD	
	340	340	340	Used attenuation	$\text{dB} * (-10)/$ measuring cycle	2 Byte	WORD	
	342+344	342	342	Used integration time	$\mu\text{sec}/$ measuring cycle	4 Byte	DWORD	
	346+348	346	346	Optimal integration time	$\mu\text{sec}/$ measuring cycle	4 Byte	DWORD	
	350	350	350			2 Byte		
Variable; caustic measurement (read only)		352	352	Focus position x	$\mu\text{m}/$ measuring cycle	2 Byte	WORD	+/-
		354	354	Focus position y	$\mu\text{m}/$ measuring cycle	2 Byte	WORD	+/-
		356+358	356+358	Focus position z	$\mu\text{m}/$ measuring cycle	4 Byte	DWORD	+/-
		360	360	Focus radius combined	$\text{m}^* \text{E}-7/$ measuring cycle	2 Byte	WORD	
		362	362	Focus radius in x	$\text{m}^* \text{E}-7/$ measuring cycle	2 Byte	WORD	
		364	364	Focus radius in y	$\text{m}^* \text{E}-7/$ measuring cycle	2 Byte	WORD	
		366+368	366+368	Focus position zx	$\mu\text{m}/$ measuring cycle	4 Byte	DWORD	+/-
		370+372	370+372	Focus position zy	$\mu\text{m}/$ measuring cycle	4 Byte	DWORD	+/-
		374	374	Divergence angle (mrad)	$\text{rad}^* \text{E}-5/$ measuring cycle	2 Byte	WORD	
		376-383	Reserve		8 Byte			
Variable; power measurement (read only)	352+354	376+378	384+386	Remaining capacity		4 Byte	DWORD	
	356+358	380+382	388+390	Absorber temperature		4 Byte	DWORD	
	360+362	384+386	392+394	Housing temperature 1		4 Byte	DWORD	
	364+366	388+390	396+398	Housing temperature 2		4 Byte	DWORD	
	368+370	392+394	400+402	Housing temperature 3		4 Byte	DWORD	
	372+374	396+398	404+406	Measured energy		4 Byte	DWORD	
	376+378	400+402	408+410	Measured power		4 Byte	DWORD	
	380+382	404+406	412+414	Measured irradiation time		4 Byte	DWORD	
	384+386	408+410	416+418	Measured power uncorrected		4 Byte	DWORD	
388+390	412+414	420+422	Temperature difference		4 Byte	DWORD		
		424 - 448	Reserve		24 Byte			

8.2 Outputs

Out	Address	Register-Address		Unit/ refresh rate	Length	Type	Sign
Command (set by PROFIBUS)	256.0	0 high	Setup 1			BOOL	
	256.1		Setup 2			BOOL	
	256.2		Setup 3			BOOL	
	256.3		Setup 4			BOOL	
	256.4		Start measurement			BOOL	
	256.5		Measurement finished -> calculate caustic			BOOL	
	256.6					BOOL	
	256.7		Reset			BOOL	
	257.0	0 low	Measurement mode: bit 0			BOOL	
	257.1		Measurement mode: bit 1			BOOL	
	257.2		Evaluation algorithm: bit 0			BOOL	
	257.3		Evaluation algorithm: bit 1			BOOL	
	257.4		Flag: unit of integration control			BOOL	
	257.5		Flag: Automatic exposure control			BOOL	
	257.6		Flag: Caustic measurement			BOOL	
	257.7		Flag: Simplified measurement			BOOL	
	258.0	1 high	Flag: external trigger			BOOL	
	258.1		Trigger mode: bit 0			BOOL	
	258.2		Trigger mode: bit 1			BOOL	
	258.3		Read setup params			BOOL	
	258.4		Save setup params			BOOL	
	258.5		Do FTP			BOOL	
	258.6					BOOL	
	258.7					BOOL	
	259.0	1 low	FPM command: start measurement			BOOL	
	259.1		FPM command: do open shutter			BOOL	
	259.2		FPM command: do close shutter			BOOL	
	259.3					BOOL	
	259.4					BOOL	
	259.5					BOOL	
	259.6		FPM command: do program			BOOL	
	259.7		FPM command: do reset			BOOL	
Single plane global settings (write only)	260	2	BeamFind: counts	counts	2 Byte	WORD	
	262	3	BeamFind: percentage	%	2 Byte	WORD	
	264	4+5	Trigger delay	µsec	4 Byte	DWORD	
	268	6	Trigger level (0-4095)	counts	2 Byte	WORD	

Out	Address	Register-Address		Unit/ refresh rate	Length	Type	Sign
Single plane variable (write only)	270	7	Attenuation; if flag "automatic exposure control" (optimizer) is set: start value for optimization	dB * (-10)	2 Byte	WORD	
	272	8+9	Integration time; if flag "automatic exposure control" (optimizer) is set: start value for optimization	µsec	4 Byte	DWORD	
	276	10			2 Byte	WORD	
	278	11	Deflect position	µm	2 Byte	WORD	
	280	12	Resolution in x	Pixel	2 Byte	WORD	
	282	13	Resolution in y	Pixel	2 Byte	WORD	
	284	14	Window size in x	µm/ measuring cycle	2 Byte	WORD	
	286	15	Window size in y	µm/ measuring cycle	2 Byte	WORD	
	288	16	Window position in x	µm/ measuring cycle	2 Byte	WORD	
	290	17	Window position in y	µm/ measuring cycle	2 Byte	WORD	
Caustic variable (write only)	292	18+19	Plane position in z	µm	4 Byte	DWORD	+/-
	296	20	Plane index (0-29)		2 Byte	WORD	
Environmental variable (write only)	298	21	Nominal laser power	W	2 Byte	WORD	

8.3 Error identifier

The error identifiers are divided into 6 groups as described below: Hardware, Parameter selection, etc. When outputting the error identifiers, it should be noted that the error identifiers within a group are added up.

In the parameter selection group, for example, the error identifier „3“ could be output. From this, it can be combined that the window is too small in X and in Y directions.

8.3.1 Error identifier hardware

Group message “Error Parameter Selection“ is set.

„Measurement Failure“ is set.

Error	Identification
Xilinx or ExtXi error	0x0001
EE-CRC incorrect	0x0002

8.3.2 Error identifier parameter selection

Group message “Error Parameter Selection“ is set.

„Measurement Failure“ is set.

Error	Error condition	Identification
Window (in X) too small	$\text{mess_x} == 0$ oder $(\text{anz_x} > 512) \&\& ((\text{mess_y}/\text{anz_y}) * \text{projection}) < (\text{pixelpitchx} * 2)$	0x0001
Window (in Y) too small	$\text{mess_y} == 0$	0x0002
Window (in X) too big/ too far to the right	$((\text{pos_x} + \text{mess_x}) * \text{projection}) > ((\text{pixelnumberx} * \text{pixelpitchx}) / 1000)$	0x0004
Window (in Y) too big/ too far up	$((\text{pos_y} + \text{mess_y}) * \text{projection}) > ((\text{pixelnumbery} * \text{pixelpitchy}) / 1000)$	0x0008
Resolution (in X) too small	$\text{anz_x} == 0$	0x0010
Resolution (in Y) too small	$\text{anz_y} == 0$	0x0020
Resolution (in X) too big (for LDS)	$\text{anz_x} > 1024$	0x0040
Resolution (in Y) too big (for LDS)	$\text{anz_y} > 1024$	0x0080
Resolution (in X) too big	$((\text{mess_x}/\text{anz_x}) * \text{projection}) < (\text{pixelpitchx})$	0x0100
Resolution (in Y) too big	$((\text{mess_y}/\text{anz_y}) * \text{projection}) < (\text{pixelpitchy})$	0x0200
smallest y-window at x_ anz==1024	$((\text{mess_y}/\text{anz_y}) * \text{projection}) < (\text{pixelpitchy} * 2)$	0x0400
Too many pixel for array sample_data	$((\text{anz_x} + 25) * \text{anz_y}) > 550000$	0x0800
Attenuation too strong	$\text{amp} < -85.1;$	0x1000
Integration time or delay too big	$\text{tInt} > 217026\mu\text{s}; \text{tDelay} > 217026\mu\text{s}$	0x2000
Inadmissible BeamFind-parameters	$\text{counts} > 4095$ or $\text{percent} > 99$	0x4000
Other inadmissible parameter	Evaluation algorithm > 1; Trigger mode > 2; Measuring mode > 3;	0x8000

8.3.3 Error identifier single plane measurement

Group message "Error Single-Plane Measurement" is set.

„Measurement Failure“ is set.

Error	Error condition	Identification
Trigger-Timeout occurred	No laser pulse within 2 s after start.	0x0001
Error with upstream measurement	Problem of FPGA process.	0x0002
Error with raw data measurement		0x0004
Error with underground measurement		0x0008
Timeout measurement	Measurement not executed within 4 s.	0x0010
		0x0020
		0x0040
		0x0080
Timeout calculation	Calculations after measurement not executed within 4 s. Possible cause: FTP transfer enabled, but no FTP server found.	0x0100
No beam found with BeamFind	Laser was off during measurement time.	0x0200
		0x0400
		0x0800
Volume negative	Beam parameters couldn't be calculated.	0x1000
beamdata.r2E < 0 (2. moments)	Sensor signal not plausible. Probably Laser was off during measurement time, or inappropriate integration time.	0x2000
beamdata.x2E < 0 (2. moments)		0x4000
beamdata.y2E < 0 (2. moments)		0x8000

8.3.4 Error identifier caustic

Group message "Error Caustic" is set.

„Measurement Failure“ is set.

Error	Error condition	Identification
No focal length presetting	No focal length transmitted.	0x0001
Plane counter: Input incorrect	Plane number < 0 or >= 30.	0x0002
Too little planes for caustic evaluation	Less than 3 planes taken during caustic measurement.	0x0004
		0x0008
		0x0010
		0x0020
		0x0040
		0x0080
Evaluation error; not calculable	Caustic fit not successful.	0x0100

8.3.5 Warning identifier single plane measurement

Group message “Warning Single-Plane Measurement“ is set.

“Irradiation failure” is set.

Warning	Warning condition	Identification
Beam on the left edge	Calculated subwindow or pos_x - r on the left edge	0x0001
Beam on the right edge	Calculated subwindow or pos_x + r on the right edge	0x0002
Beam on the lower edge	Calculated subwindow or pos_y - r on the lower edge	0x0004
Beam on the top edge	Calculated subwindow or pos_y + r on the upper edge	0x0008
Oversaturated	Raw data at impact (4095 counts) > 5 % Reference surface: Calculated beam surface (if beam radius could be calculated; otherwise: Subwindow, if BeamFind successful; otherwise: window surface)	0x0010
Undersaturated	Raw data < 2500 counts	0x0020

8.3.6 Warning identifier caustic

Group message “Warning Caustic“ is set.

“Irradiation failure” is set.

Warning	Warning condition	Identification
No power presetting	No power value or power value == 0 transmitted	0x0001
		0x0002
		0x0004
		0x0008
		0x0010
		0x0020

9 Install and configure LDS

The PRIMES LDS can be installed on the PC to operate the measuring devices. The LDS controls the measurements and returns the measurement results in graphical form. The PRIMES LDS is available on the PRIMES website at: <https://www.primes.de/de/support/downloads/software.html>.

The measuring device can be operated directly via the system without the LDS. For this, read on from chapter 11 „Measurement settings“ on page 47.

9.1 System requirements

Operating system:	Windows® 7/10
Processor:	Intel® Pentium® 1 GHz (or comparable processor)
Required hard disk space:	15 MB
Monitor:	19" recommended screen size, resolution min. 1 024 x 768
LDS version:	2.98

9.2 Install software

The software is installed menu-driven. Start the installation by double-clicking on the file „Setup LDS v.2.98.exe“ and follow the instructions.

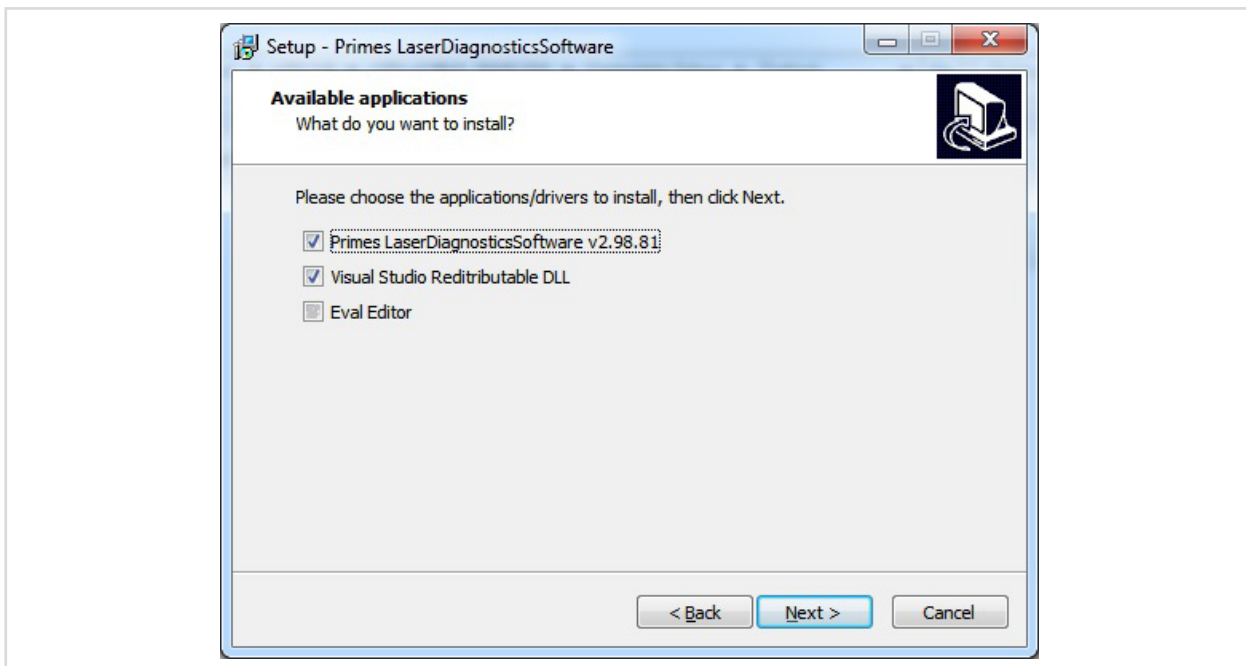

Fig. 9.1: LDS Setup

Unless otherwise specified, the installation software writes the main program “LaserDiagnosticsSoftware.exe” to the “Programs/PRIMES/LDS” directory.

In addition, the settings file „laserds.ini“ is also copied to this directory. The setting parameters for the PRIMES measuring devices are stored in the „laserds.ini“ file.

9.3 Ethernet configuration

9.3.1 Set IP address of PC



The PC must be in the same IP address range as the PRIMES device.

Choose one of the following options to establish a connection between the PRIMES device and the PC. The IP address of the PRIMES device can only be changed once this connection has been established (see chapter 9.3.2 „Change IP address of a connected device“ on page 39).

Integration of a PRIMES device into a network

Within the PRIMES device, the option DHCP (Dynamic Host Configuration Protocol) is activated by default. The device obtains its IP address from the DHCP server.

Direct connection of a PRIMES device to a PC

In **Windows > Control panel > Network and Sharing Center**, assign an IP address to your PC that is in the same address range as the PRIMES device (e.g. 192.168.116.xyz). The first three number blocks must be identical, the last number block (0-255) can be freely selected. The static IP address on the identification plate of the PRIMES device cannot be used for the PC. The IP address should be entered by a system administrator.

The static IP address of your PRIMES device can be found on the identification plate.

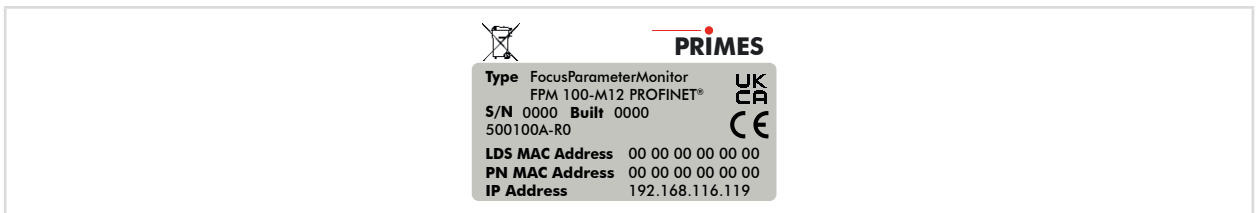

Fig. 9.2: Identification plate using the FPM 100-M12 PROFINET as example

9.3.2 Change IP address of a connected device

Within the device a static IP address is stored and the function **Use DHCP** is activated. When establishing a connection, the device will first wait to be assigned a suitable IP address via DHCP. If this proves unsuccessful, it will revert to the static IP address.

If **Use DHCP** is disabled, the device will directly use the static IP address. As a result, the connection can be established faster.

For a connected device, both the IP address and the activation of DHCP can be changed.



If the PRIMES device is connected directly to a PC (without network), the IP address of the PRIMES device and the PC must be in the same address range. If a static IP address is selected that is outside the address range of the PC and DHCP is also deactivated, the device can no longer be addressed.

To reconnect to the PRIMES device, the IP address of the PC must be changed (see chapter 9.3.1 „Set IP address of PC“ on page 39). Both devices must be in the same address range.

9.3.3 Establishing a connection to FPM

1. Start the LDS.
2. Open the **Communication > Free Communication** dialog window.
3. Select "TCP" in the **Mode** field (the **Second IP** option must not be activated!).
4. In the **TCP** field, enter the IP address.
5. Click the **Connect** button ("Connected" appears in the bus monitor).
6. Check the **Write bus log** box (the log can be very useful when encountering problems):
 - ➔ The log is stored in the installation directory of the LDS.
 - ➔ The file name is buspro.log.YYYY.MM.DD (YYYY.MM.DD = date the file was created).
7. Click the **Save Config** button (the configuration is saved and does not need to be re-entered when restarting the LDS).
8. Click on the **Find PRIMES Devices** button:
 - ➔ If a device is found, the dialog windows for the measurement settings are opened.

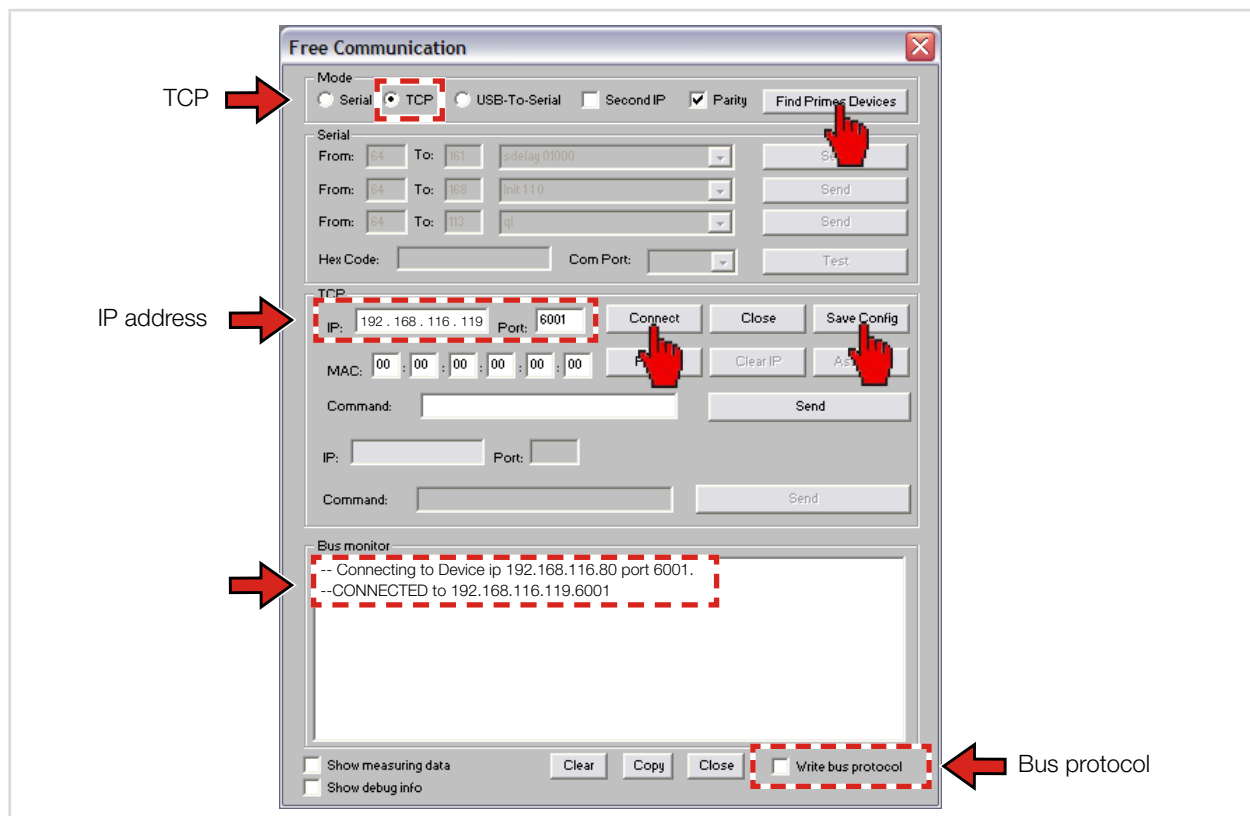

Fig. 9.3: Establish a connection to the PC in the **Free Communication** dialog window



The FPM has a fixed IP address that is specified on the type plate:

- If the FPM is connected directly to the PC, enter the fixed IP address in the menu **Communication > Free Communication**.
- If the FPM is connected via a network, the FPM retrieves a variable IP address in the network for around one minute. This variable IP address can be retrieved with the provided software, "PrimesFindIp" and entered into the **Communication > Free Communication**.
- To connect the FPM to the network using the fixed IP address, first turn on the FPM and then connect the network cable to the FPM. Then enter the fixed IP address in the menu **Communication > Free Communication**.

9.3.4 Obtain an IP address automatically with DHCP

DHCP (Dynamic Host Configuration Protocol) enables a device to be automatically integrated into an existing network without manual configuration.

Activate the DHCP function in the LaserDiagnosticsSoftware with the command: se0332 ★ 001

(The „★“ in the command represents a space.)

1. Start the LDS.
2. Open the **Communication > Free Communication** dialog window.
3. In the **Mode** field, select **TCP** (the **Second IP** option must not be activated!).
4. In the **TCP** field, enter the current **IP** address.
5. Click the **Connect** button (“Connected” appears on the bus monitor).
6. Check the **Write bus protocol** box (the protocol can be very useful when encountering problems):
 - ➔ The log is stored in the installation directory of the LDS.
 - ➔ The file name is buspro.log.YYYY.MM.DD (YYYY.MM.DD = date the file was created).
7. Enter the following command in the **Command** input field: se0332 ★ 001
8. Click on the **Send** button and wait for the confirmation on the **Bus monitor** (see Fig. 9.4 on page 41 „- > Adr:0332 Wert: 001“)
9. Turn the device off and on again.

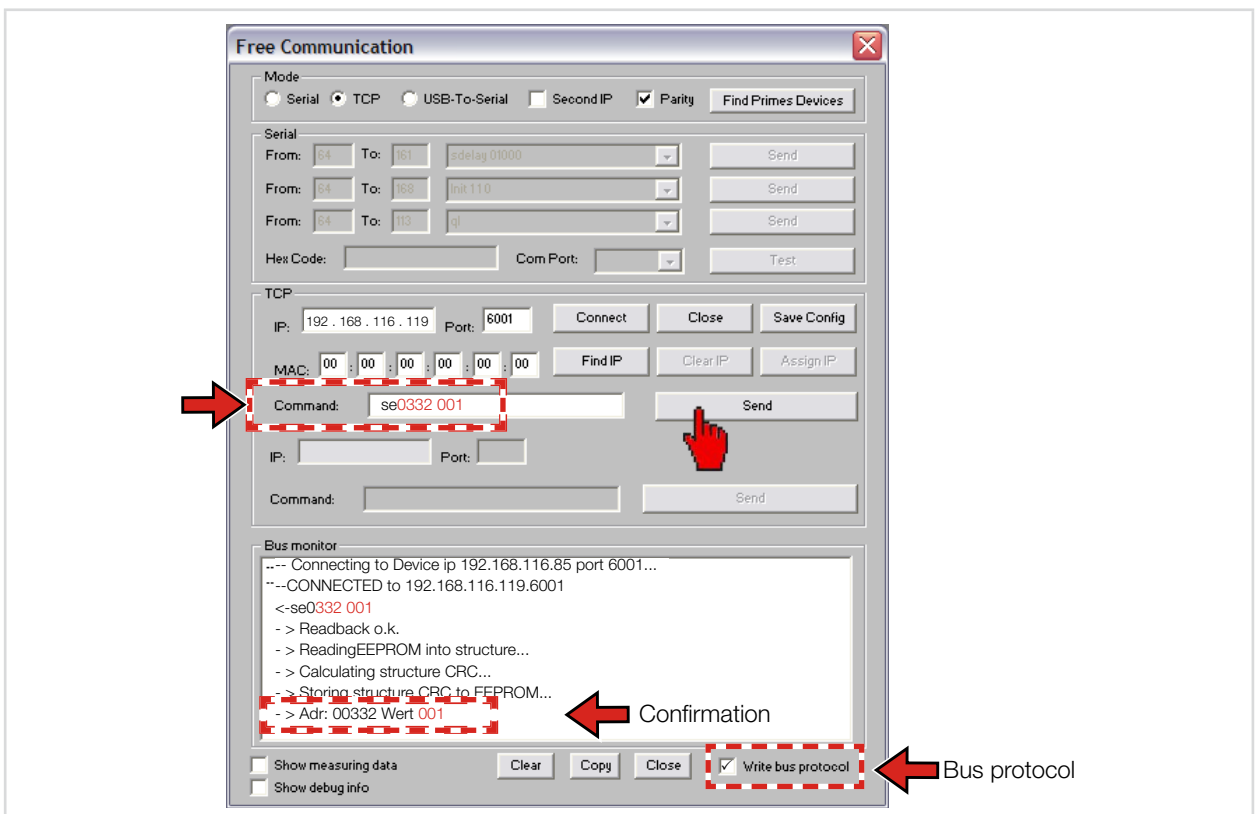

Fig. 9.4: Enable DHCP in the Free Communication dialog box

After restarting the device in the network, a new IP address is requested and automatically assigned by the server/router. The **FindIP** function via the MAC address cannot be executed in this case.

If there is no connection to the network (no response from the server), the static IP address (see type plate) is activated in the FPM until it is restarted again.

The DHCP function can be disabled with the command **se0332 ★ 000**.

10 Description of the LDS

The LDS is the control center for all PRIMES measuring devices that measure the beam distribution as well as focus geometries by means of which the beam propagation characteristics can be determined.

The LDS includes all functions necessary for the control of measurements and displays the measuring results graphically.

Moreover, the system evaluates the measured data in order to give the operator information regarding the reliability of the measuring results.

Please start the program by double-clicking the PRIMES symbol  in the new start menu group or the desktop link.

10.1 Graphical user interface

First, a start window is opened to choose whether to measure or just display an existing measurement (factory setting "Measure").

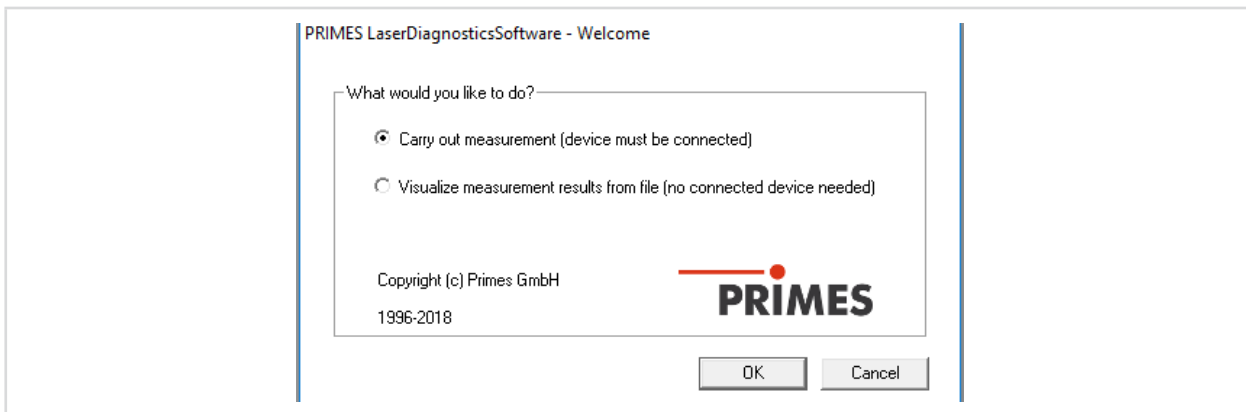

Fig. 10.1: Start window of the LDS

After the detection of the connected device, the graphical user interface and several important dialogue windows are opened.

The graphical user interface essentially consists of a menu bar and a toolbar, which can be used to call up various dialog or display windows.

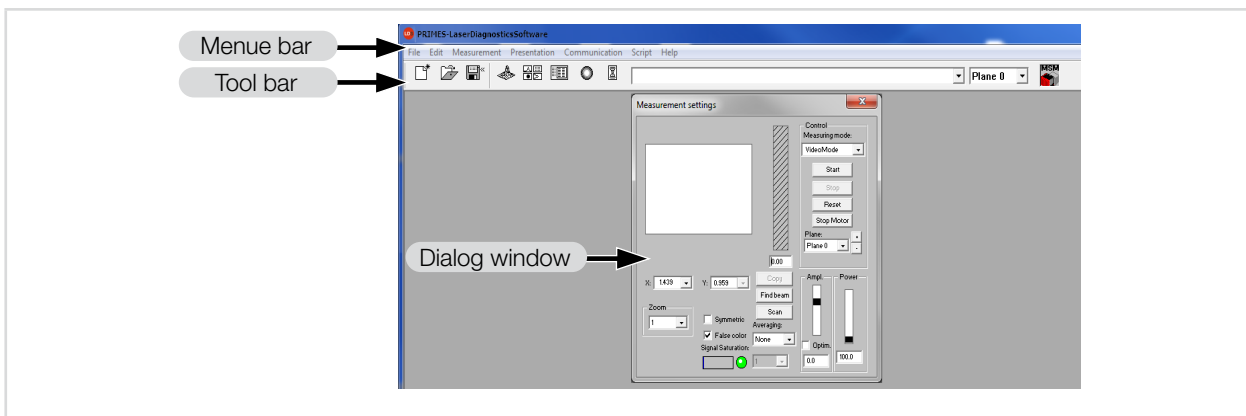

Fig. 10.2: Main elements of the user interface

It is possible to open several measuring and dialogue windows simultaneously. In this case, windows that are basically important (for the measurement or the communication) remain in the foreground. All other dialog windows fade into the background as soon as a new window opens.

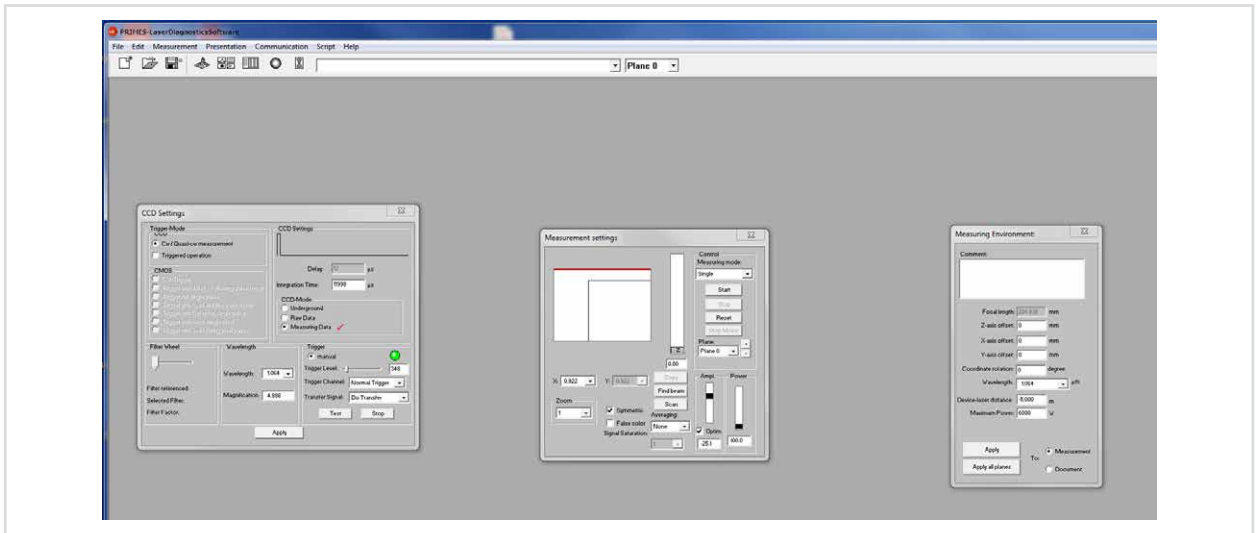

Fig. 10.3: Main dialogue windows

10.1.1 The menu bar

In the menu bar, all main and sub menus offered by the program can be opened.

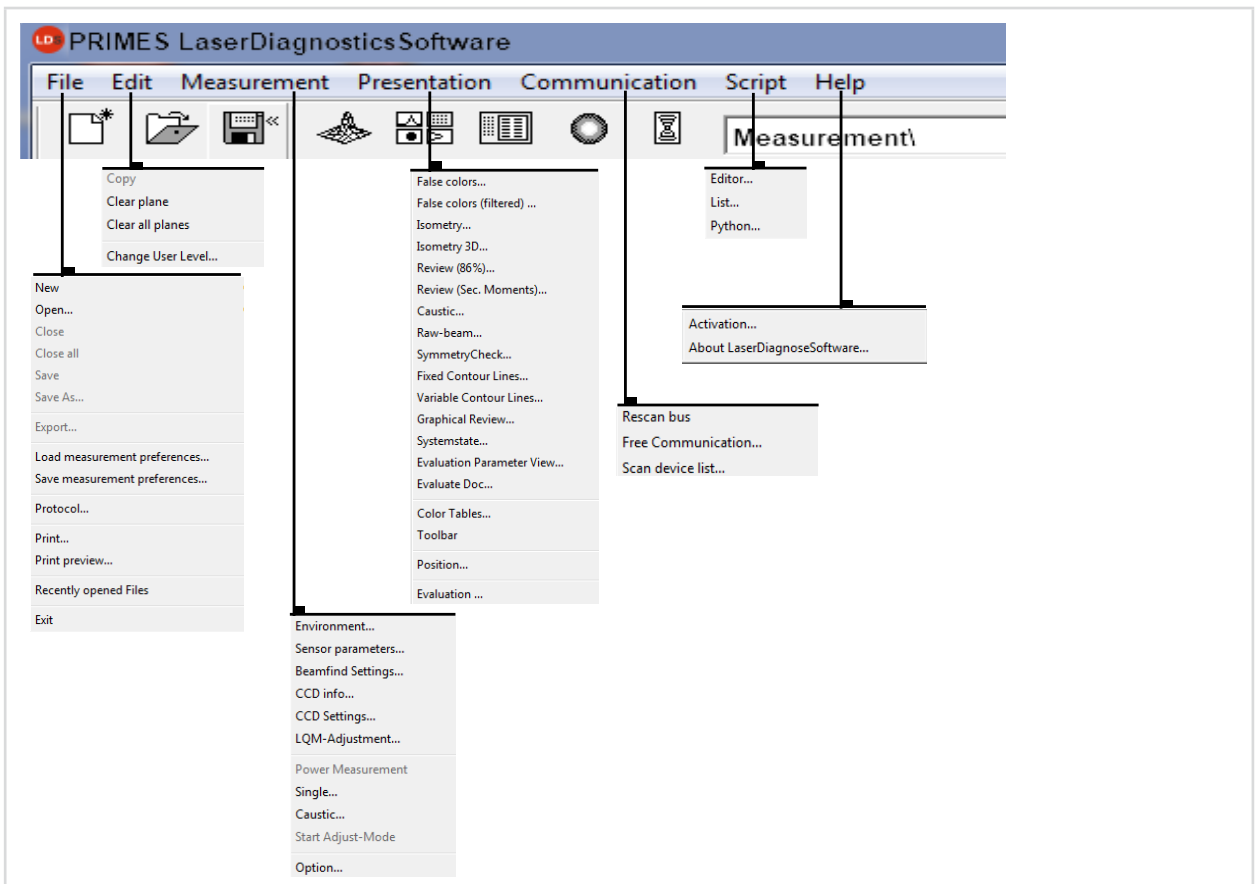

Fig. 10.4: Menu bar

10.1.2 The toolbar

By clicking the symbols in the toolbar, the following program menus can be opened.

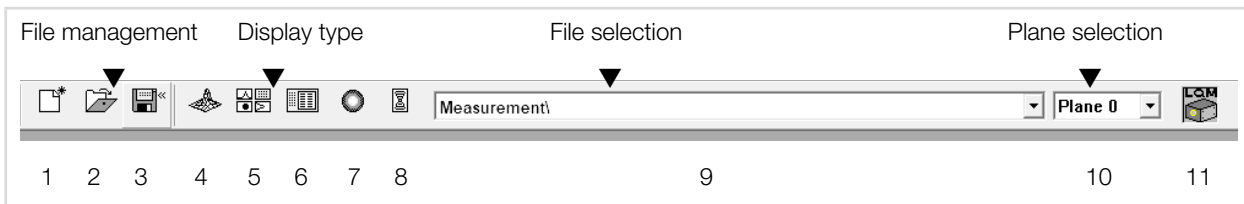

Fig. 10.5: Symbols in the toolbar

- 1 - Create a new data record
- 2 - Open an existing data record
- 3 - Save the current data record
- 4 - Open the isometric view of the selected data record
- 5 - Open the variable contours line view
- 6 - Open review (86%)
- 7 - Open false color depiction
- 8 - Caustic presentation 2D
- 9 - List with all data records opened
- 10 - Display of the selected measuring plane
- 11 - Display of the measuring devices available for the bus by means of graphical symbols

All measuring results are always written into the document selected in the toolbar. Only documents that are selected here can be displayed. After opening, the data set has to be explicitly selected.

10.1.3 Menu overview

File	
New	Opens a new file for the measuring data
Open	Opens a measuring file with the extensions “.foc” or “.mdf”
Close	Closes the file selected in the toolbar
Close all	Closes all files opened
Save	Saves the current file in foc- or mdf format
Save as	Opens the menu for storing the files selected in the toolbar. Only files with the extensions “.foc” or “.mdf” can be imported reliably
Export	Exports all current data in protocol formats “.xls” and “.pkl”
Load measurement preferences	Opens a file with measurement settings with the extension “.ptx”
Save measurement preferences	Opens the menu to save the settings of the last program run. Only files with the extension “.ptx” can be opened
Protocol	Starts a protocol of the numeric results. They can either be written into a file or a data base
Print	Opens the standard print menu
Print preview	Shows the content of the printing order

File	
Recently opened files	Shows the file opened before
Exit	Terminates the program

Edit	
Copy	Copies the current window to the clipboard
Clear plane	Deletes the data of the plane selected in the toolbar
Clear all planes	Deletes all data of the file selected in the toolbar
Change user level	By entering a password a different user level can be activated.

Measurement	
Environment	Different system parameters can be entered, e.g. <ul style="list-style-type: none"> - Reference value for the laser power - Focal length (Not relevant for FPM) - Wavelength - Comment - Device offset (distance FPM - beam source)
Sensor parameters	The following device parameters can be e.g. set here: <ul style="list-style-type: none"> - The spatial resolution (32, 64, 128 or 256 Pixel) - The manual settings of the z-axis - Choosing the measuring devices connected to the bus - Deactivating the z-axis
Beamfind settings	Setting parameter for a beamfind procedure
CCD info	Provides information on device parameters
CCD settings	Special settings can be made, e.g.: <ul style="list-style-type: none"> - Trigger mode - Trigger level - Exposure time - Wavelength
LQM-Adjustment	Not relevant for FPM
Power measurement	Not relevant for FPM
Single	This menu item enables the start of single measurements, of the monitor mode and the video mode
Caustic	Not relevant for FPM
Start adjustment mode	Not relevant for FPM
Options	Enables the setting of device parameters

Presentation	
False colors	False color display of the spatial power density distribution
False colors (filtered)	Usage of a spatial filtration (spline function) on the false color display of the power density distribution
Isometry	3-dimensional display of the spatial power density distribution

Presentation	
Isometry 3D	Allows a 3D display of caustic and power density distribution with spatial rotation as well as an optional isophote display
Review (86%)	Numerical overview of measuring results in the different layers based on the 86% beam radius definition
Review (2. Moments)	Numerical overview of the measuring results in the different layers based on the 2 nd moment beam radius definition
Caustic	Results of the caustic measurement and the results of the caustic fit – such as beam quality factor M^2 , focus position and focus radius
Raw beam	Not relevant for FPM
Symmetry check	Not relevant for FPM
Fixed contour lines	Display of the spatial laser density distribution with fixed intersection lines for 6 different power levels
Variable contour lines	Display of the spatial power density distribution with freely selectable intersection lines
Graphical review	Enables a selection of graphical displays – among them the radius, the x- and y- position above the z-position and the time
System state	Not relevant for FPM
Evaluation parameter	Loading stored evaluation parameters
Color tables	Different color charts are available in order to analyse e.g. diffraction phenomena in detail
Toolbar	In order to display or to hide the toolbar
Position	Moving the device into a defined position
Evaluation	Comparison of the measured values with defined limit values and evaluation (optionally)
Communication	
Rescan bus	The system searches the bus for the different device addresses. This is necessary whenever the device configuration at the PRIMES bus was changed after starting the software.
Free Communication	Display of the communication on the PRIMES bus
Scan device list	Lists the device addresses of the single PRIMES devices
Script	
Editor	Opens the script generator, a tool for automatically controlling complex measurement sequences (with a script language developed by PRIMES).
List	Shows a list of the opened windows
Python	Opens the script generator in order to control complex measuring procedures automatically (scripting language Python)
Help	
Activation	Enables the activation of special functions
About LDS	Provides information regarding the software version

Tab. 10.1: Menu overview

11 Measurement settings

11.1 Warning messages



DANGER

Serious eye or skin injury due to laser radiation

If the shutter is not opened before the laser is switched on, directional reflections of the laser beam will occur (laser class 4).

- ▶ Make sure that the shutter of the device is open.
- ▶ Please wear **safety goggles** adapted to the power, power density, laser wavelength and operating mode of the laser beam source in use.
- ▶ Wear suitable **protective clothing** and **protective gloves**.
- ▶ Protect yourself from laser radiation by separating protective devices (e.g. by using appropriate shielding).



DANGER

Serious eye or skin injury due to laser radiation

If the system is operated with a power density that is too high, the protective window or the optics can be destroyed. This can lead to reflections of the laser beam (laser class 4).

- ▶ Note the maximum power density (60 mm below the entrance aperture) of 1 MW/cm² specified in the technical data.

An over- or underexposed measurement can lead to incorrectly determined radii. In the case of severely underexposed measurements, beam search errors can occur.

For these reasons, the exposure time must be determined before the measurement is started. The preset measuring parameters can be used or a set-up can be defined.

A setup can be created in two different ways:

- Enter measurement parameters with the LDS or
- Enter measurement parameters via the PLC

Then determine the exposure time. There are two options for this:

- Determine exposure time with the LDS or
- Determine exposure time via the PLC

11.2 Enter measurement parameters with the LDS

11.2.1 Establish connection

To create a setup with the PRIMES LDS an Ethernet connection of the FPM to the computer (or network) must be available and the software must be installed on a windows based PC.

See chapter 9.3 „Ethernet configuration“ on page 39.

11.2.2 Sensor parameters

- ▶ Set a resolution of 512 x 512 pixels in the **Sensor parameters** dialog box.

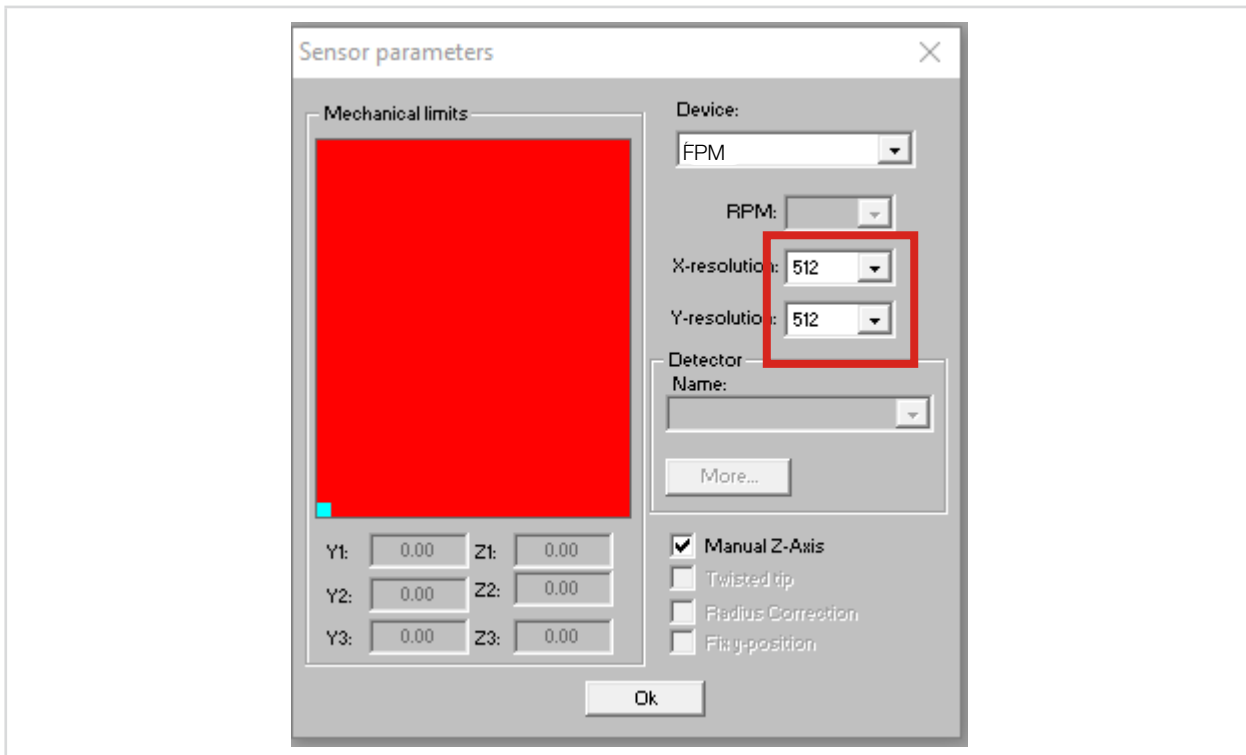

11.2.3 Measurement window

1. In the **Measurement settings** dialog box, select the largest possible setting for the measurement window:

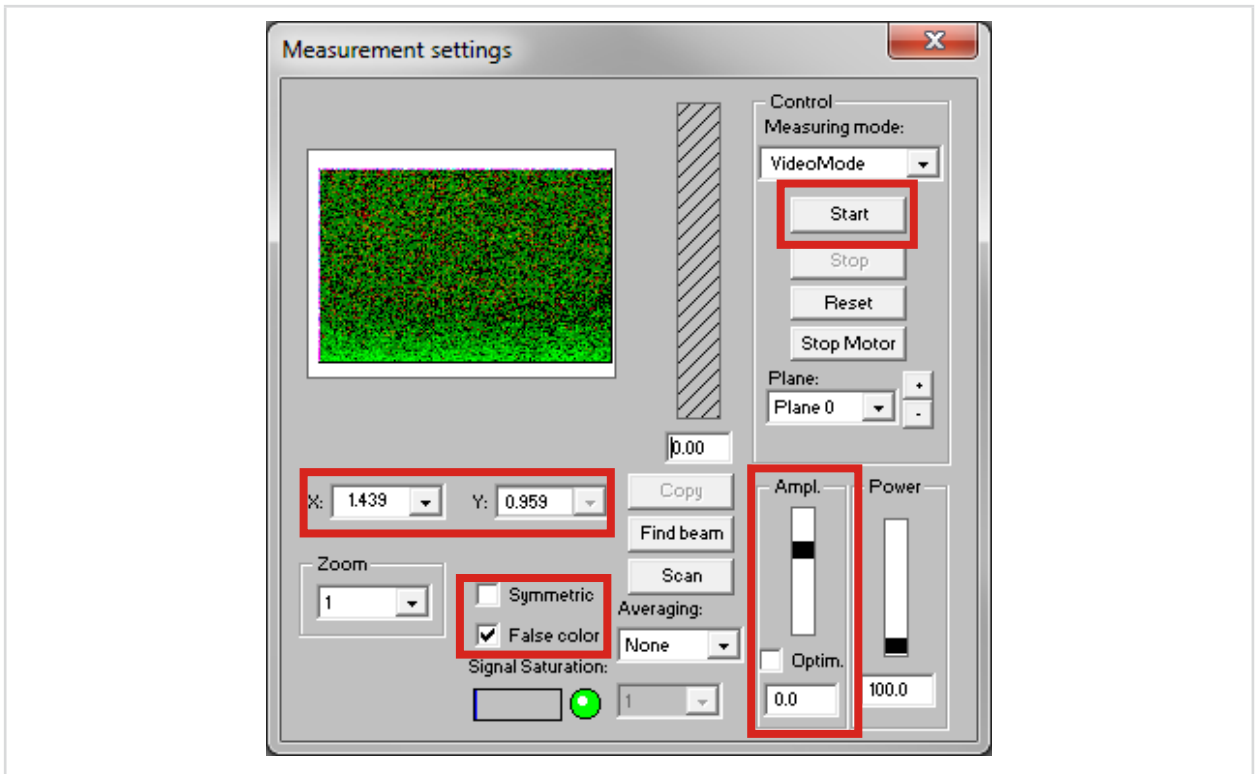

2. Clear the **Symmetric** and **Optim.** check boxes (check mark must not be set).
 3. Activate **False color** for better interpretation.
 4. Choose the largest possible measurement window.
 5. Position the window in the middle.
 6. Press **Start**.
- ➔ The FPM carries out the measurement and thus accepts all the settings made.

11.2.4 The command line „Command“

The FPM is controlled via the command line in **Communication > Free Communication**.
The following commands are used during the installation:

- profiMeas
- svSetup

profiMeas

The profiMeas command sets the measurement mode when connected to the LDS.
The measurement with the PLC (if available) is not affected.

Syntax:

The „★“ in the command represents a space.

profiMeas ★ 0 normal Measurement

profiMeas ★ 1 ★ xx simulated PLC measurement with setup 1 to 4 (xx: 01 - 04).
The measurement is performed as if the measurement was triggered by the PLC.

profiMeas ★ 1 ★ xx ★ Aa ★ Tt ★ BF ★ cccc ★ pp ★ Mm ★ FTPf

- simulated SPS measurement with the parameters defined above
- xx: Setup-Number (00 - 04)
- A: Evaluation algorithm (a=0 for 2. Moment, a=1 for 86%)
- T: Trigger-Mode (0= untriggered, 1= classic, 2=SZ-triggering=single shot)
- BF: Beamfind (cccc= Beamfind-Level, pp= Beamfind percentage %)
- M: Measuremet mode

0= raw data, background, diffusion compensation measurement

1= raw data

2= underground

3= raw data and immediately afterwards background (without further trigger)

profiMeas ★ 2 ★ z does not start a measurement, but loads the last measured value from the memory.
Can be used to review the last measurement (z=0 mess data, z=1 raw data).

svSetup

The svSetup command is used to save and change setups in the FPM. All settings such as window size, resolution, window position are taken from the LDS. Make sure these are set correctly!

Syntax:

svSetup ★ xx ★ Aa ★ Tt ★ BF ★ cccc ★ pp ★ Mm ★ FTPf

xx: Setup Number (00 - 04)

- A: Evaluation algorithm (a=0 for 2. Moment, a=1 for 86%)
- T: Trigger-Mode (0= untriggered, 1= classic, 2=SZ-triggering=single shot)
- BF: Beamfind (cccc= Beamfind-Level, pp= Beamfind percentage %)
- M: Measurement mode

0= raw data, background, diffusion compensation measurement

1= raw data

2= underground

3= raw data and immediately afterwards background (without further trigger)

11.2.5 Creating setups

To change and save setups, proceed as follows:

1. Choose again **Communication > Free Communication**.
2. Type the following commands into the **Command** line and press the **Send** key after each command. The „★“ in the command represents a space.
 - svSetup ★01 ★A0 ★T2 ★BF ★0200 ★30 ★M3
 - svSetup ★02 ★A0 ★T2 ★BF ★0200 ★30 ★M3
 - svSetup ★03 ★A0 ★T2 ★BF ★0200 ★30 ★M3
 - svSetup ★04 ★A0 ★T2 ★BF ★0200 ★30 ★M3

A confirmation of the successful saving is displayed in the lower text box.

The setups are now created and ready for testing. They are all the same, the only parameter that will change later in use is the gain.

To adjust the gain, do the following before saving a setup:

3. Clear the **Optim.** check box (check mark must not be set).
 4. Set the gain in the measurement settings.
 5. Press **Start**.
- ➔ This sets the gain on the device.

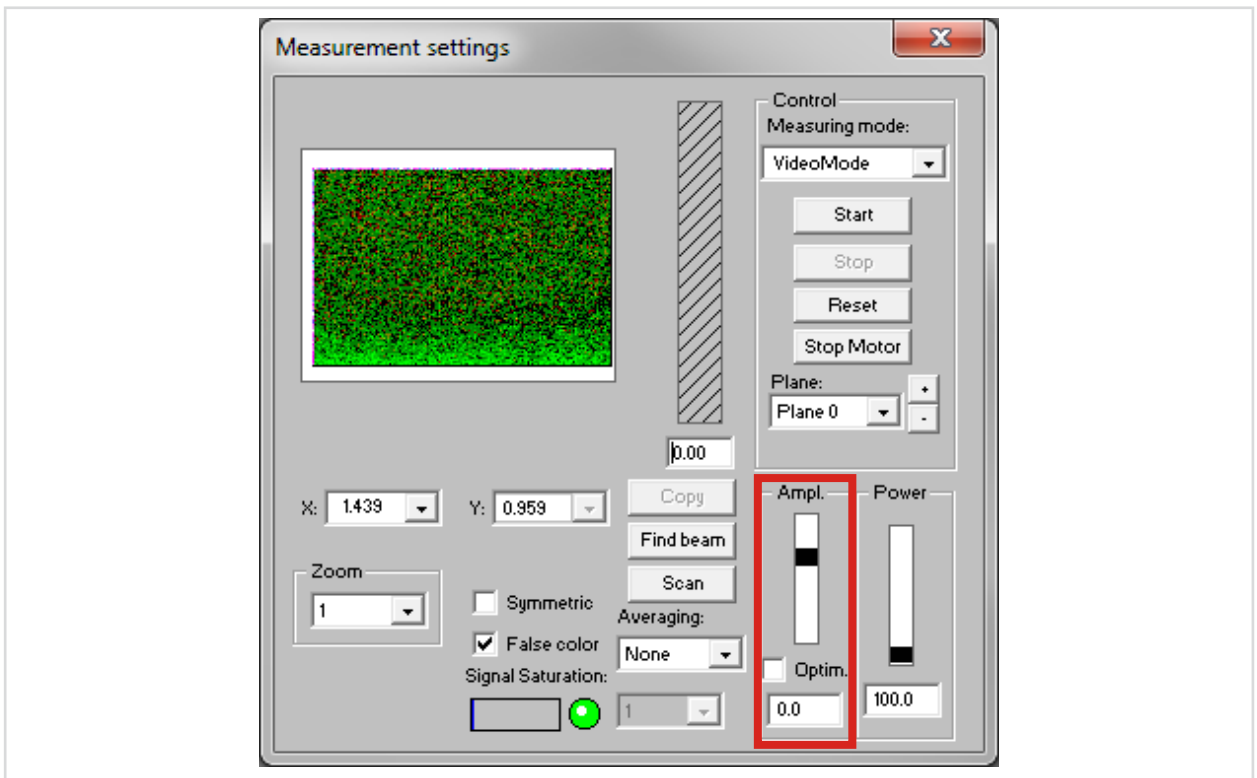

Set the gain manually by sending the following command:

svSetup ★xx ★amp ★yyy

where **xx** is the setup number (01 to 04) and **yyy** is the gain level (200 to 800).

The gain is set with a factor of -10, which means -20dB in the software corresponds to 200 here.

11.2.6 Checking the beam position

1. Go to **Communication > Free Communication**.
2. Enter the following command: profiMeas *2 *0. The „*“ in the command represents a space.
3. Then click **Send**.

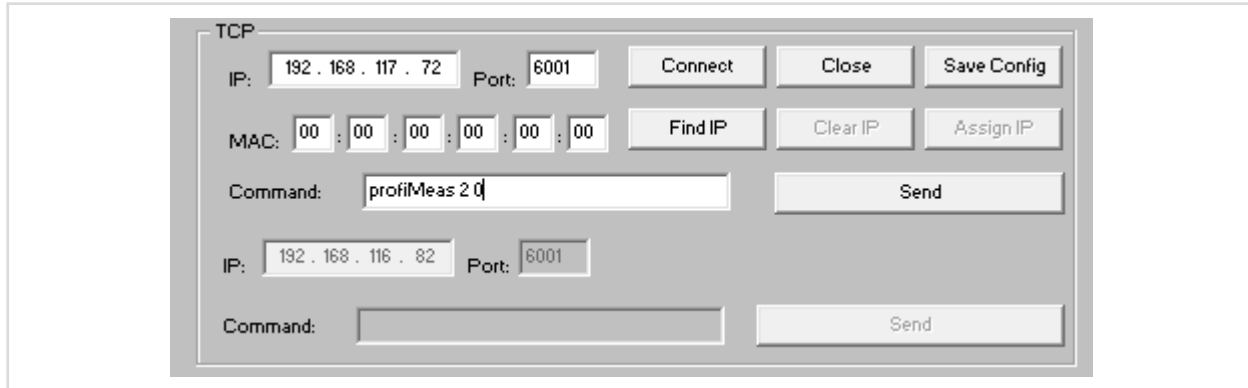

Now a measurement can be triggered via the system. As soon as the measurement is finished, press **Start** in the measurement settings.

The FPM then displays the last level measured.

In order to get a better representation, planes can be enlarged. To do this, click on the following button:

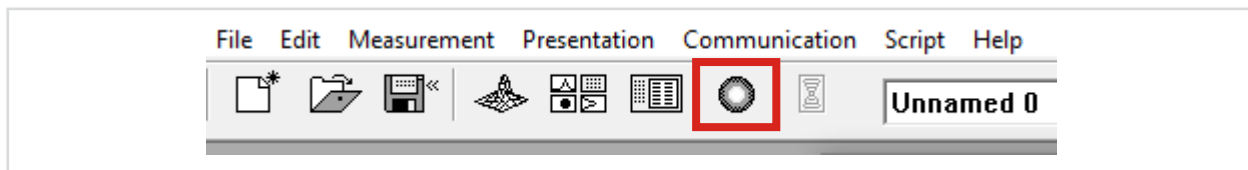

After checking, close the software.

11.3 Enter measurement parameters via the PLC

Four different measurement settings (setups) can be saved using bits 256.0 to 256.3. In order to carry out a measurement with the saved settings, the bit corresponding to the setup must then be set to 1.

If none of these bits is set to 1, the measurement is carried out with the parameters stored in the controller (address 256.5 to 276, see chapter 8.2 „Outputs“ on page 33).

i The system must not have “SaveSetupParams”, “Start Measurement” or “Calc Caustic” set as the initial situation. The FPM must be in the “idle” operating state.

System	FPM
Sets setup/measurement parameters	
Sets "ReadSetupParams"	
	Reads parameters for the setup
	Sets "SetupParamsRead"
	Delete "Idle"
Delete "ReadSetupParams"	
Sets "SaveSetupParams"	
	Delete "SetupParamsRead"
	Sets "Idle"
Delete "SaveSetupParams"	

11.4 Determine exposure time with the help of the LDS

The following procedure is recommended to set the exposure time using the LDS. The exposure time corresponds to the amplification of the FPM.

Several consecutive measurements are usually required to determine the exposure time.

Before each additional laser pulse (before each measurement), check the remaining capacity of the absorber. The value of the remaining capacity is sent via the PLC.

11.4.1 Preparation

To adjust the gain, the FPM must already be adjusted to the laser beam and the laser beam must hit the CCD as centrally as possible.

Gain adjustment should be done at process power. However, the FPM may only be irradiated in individual pulses, not in continuous operation (cw operation).

Before adjusting the setting, gain optimization in the LDS must be turned off. This function is not supported by the FPM.

- ▶ Clear the *Optim.* check box (check mark must not be set)

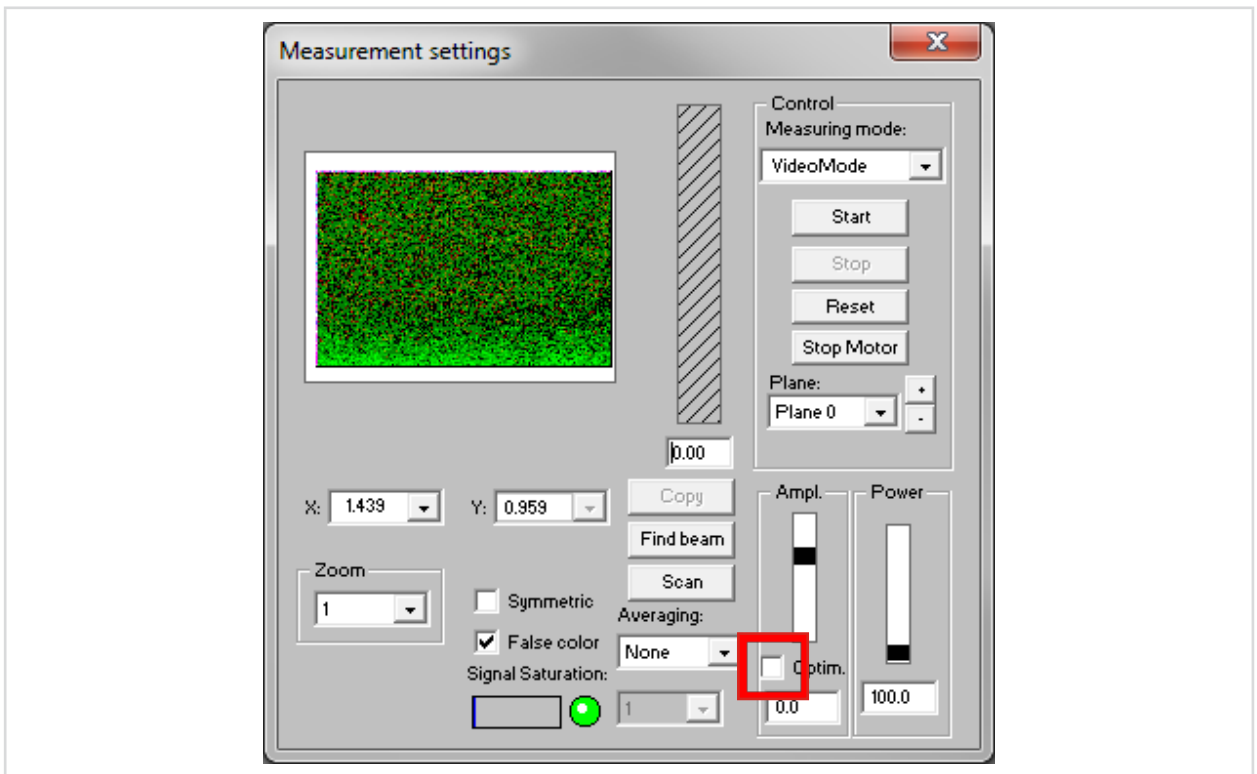

Fig. 11.1: Setting the gain via the measurement settings

In order to be able to set the gain, a measurement must be triggered. This can either be done via the PLC or triggered manually on the laser (with the correct parameters).

11.4.2 Triggering a manual measurement

To trigger a manual measurement, proceed as follows. The „★“ in the command represents a space.

1. Bring the FPM into the simulated SPS measuring mode:
(profilMeas ★ 1 ★ 00 ★ A0 ★ T2 ★ BF ★ 0200 ★ 30 ★ M3).
2. Start the measurement in the LDS.
3. Trigger the laser within 2 seconds.

11.4.3 Setting the gain

Historically, the optical amplification is set in the LDS. With the FPM, the exposure time of the CCD sensor is set here.

The exposure time depends on the power density of the laser. The power density changes with the laser power and the beam diameter. When measuring a caustic, the beam diameter and thus also the power density change along the direction of propagation of the laser.

The set amplification therefore depends on:

- laser power
- beam diameter
- position in the beam (along the direction of propagation)

The level of the signal should be around 3 000 counts. This will give enough leeway so that the signal level does not immediately fall above or below the limit values when changing the parameters mentioned.

Above 4 095 counts the signal is oversaturated, under 2 500 counts the signal level is too low.

To check the signal level, use the detailed view of the measurement plane.

► Open the measurement plane detail view:

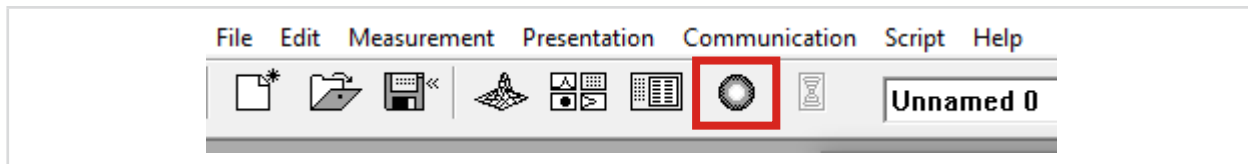

The following window opens:

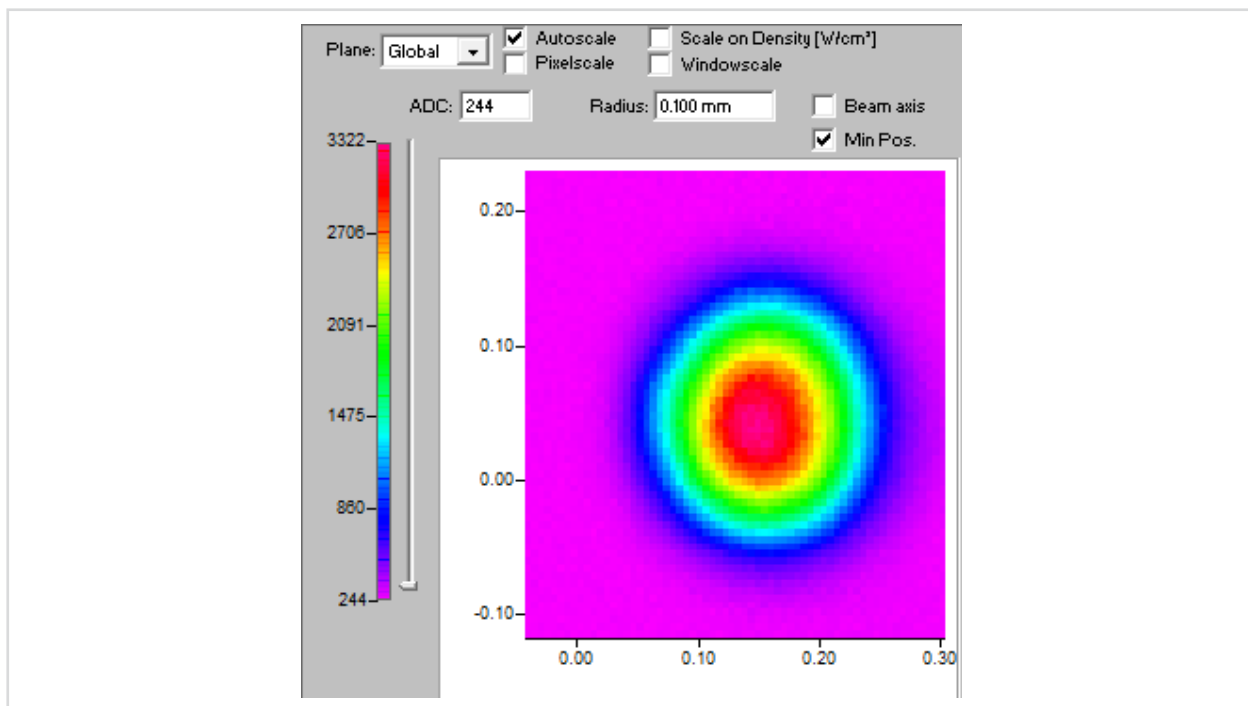

Fig. 11.2: Detail view of a measurement plane with scaling

In the detailed view the color scale of the displayed measurement plane can be seen on the left-hand side. The scaling is always scaled to the highest level. The upper end of the scale should be around 3 000 counts.

If the signal level is not in the desired range, adjust the gain and repeat the plane measurement.

11.5 Determine the exposure time via the PLC

Several consecutive measurements are usually required to determine the exposure time.

Before each additional laser pulse (before each measurement), check the remaining capacity of the absorber. The value of the remaining capacity is sent via the PLC.

NOTICE

Damage/destruction of the device due to excess temperature

If the remaining energy input is not taken into account before each measurement, the absorber can be damaged or destroyed.

- ▶ Check the remaining capacity (variable "FPM result: remaining_capacity") and the absorber temperature ("FPM result: absorber temperature) before triggering a measurement process (in the case of caustic measurements before each individual plane measurement).
- ▶ Also note any overtemperature warnings from the device (flag „FPM status: too hot“ is set)

Example:

With a laser power of 2 kW and an exposure time of 200 ms, the energy of 400 J is absorbed.

$$E = P \cdot t = 2\,000\text{ W} \cdot 0,2\text{ s} = 400\text{ J}$$

The FPM is designed for measuring short-term exposure and has no automated exposure time adjustment. The appropriate exposure time must therefore be determined for the various beam configurations.

The combination of the parameters and measurement results transferred via the fieldbus offers the opportunity to do this.

The setting based on the transmitted results should be shown and explained here.

No settings are required for the power measurement apart from making the device ready to measure. Only the parameters relevant for setting the exposure time are taken into account. The remaining settings are not changed during the process and are set as follows:

Address	Parameter	Value	Comment
268	Trigger level	2000	Fixed value for pulse detection [cts].
264	Trigger delay	0	Delayed start of measurement [μ s]
270	Attenuation	0	[dB]; not used here
276	Beam position z	0	Only for documentation [μ m]
260	BeamFindCounts	200	Settings for beam search
262	BeamFindPercent	30	
280	Resolution X	512	Maximum resolution
282	Resolution Y	512	
284	Window size x	2240	Maximum asymmetric measurement window
286	Window size y	1493	Attention - device specific: values are noted on the device.
288	Window position x	0	Offset for centering the measuring window on the camera chip
288	Window position y	0	

Address	Parameter	Value	Comment
256.0	setup 1	0	No setup use
256.1	setup 2	0	
256.2	setup 3	0	
256.3	setup 4	0	
257.0	Measuring mode 0	FALSE	Normal measurement with measurement result transfer
257.1	Measuring mode 1	FALSE	
257.2	Evaluation 0	FALSE	valuation with 2nd moments
257.3	Evaluation 1	FALSE	
257.4	Integration time Unit	TRUE	Exposure is controlled via exposure time
257.5	Automatic exposure	FALSE	Deactivated, because single pulse measurement
257.7	Simplified measurement	TRUE	Mode for single pulse measurement
258.0	External trigger	FALSE	Use of integrated pulse detection
258.1	Trigger mode 0	FALSE	Disable cw measurement
258.2	Trigger mode 1	TRUE	
258.3	Read setup parameters	FALSE	Handshake signals for saving a setup
258.4	Save setup parameters	FALSE	

The correct integration and implementation of the measurement process is required (e.g. the handshake to trigger a measurement). The individual measurement sequences are described in detail in chapter 12.1 „Measuring procedure“ on page 61 and then shown in timing diagrams.

Required control parameters (OUT):

Address	Parameter	Value	Comment
272	Exposure time	20000	[μ s]; 20ms as initial value

Required result parameters (IN):

Address	Parameter	Comment
326	% Override	percentage area of the measured beam is overridden
342	Exposure time used	[μ s]; value as specified in the output
346	Optimal exposure time	optimal exposure time calculated from the measurement
282.5	Irradiation failure	general warning during measurement
292	WarnSingle	warning code for the last measurement

The internal evaluation uses the results of a measurement to calculate the ideal exposure time. For this approximately 3 300-3 500 cts are achieved in the measurement in order to balance out minimal fluctuations in output.

When the exposure time is close to the optimum, i.e. there is only slight over - or underexposure, this calculation provides reliable values.

If the exposure time is too long, several iterative steps are necessary in order to reach the optimal range.

If the exposure time is too short, there may not be enough of a signal to facilitate an evaluation. The resulting values will then be unrealistic and the optimal setting for the exposure time incalculable.

It is therefore better to start with overly long exposure times and several steps until the optimum setting has been determined.

The following example starts off with the longest possible exposure time, with the FPM already delivering good measurement results.

Exposure times of 200 μ s and 35 ms are used as a reference point for usable measurements.

To illustrate the optimization process, the measurement data for each iteration step is read out and listed. To graphically illustrate the changes, the results are also shown as excerpts from the display in the PRIMES LDS software.

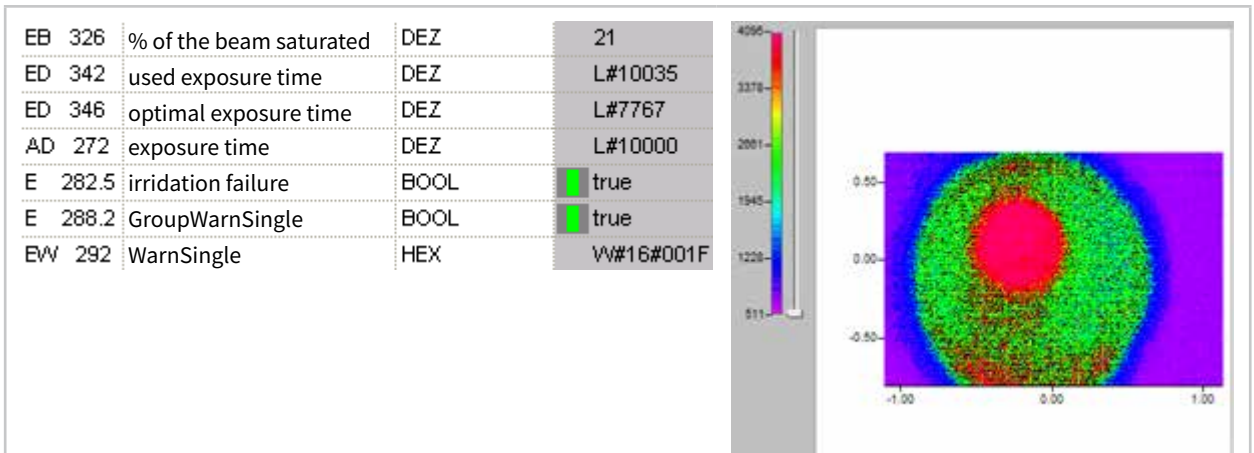

Here the measurement is overmodulated and the beam reaches out to the edge of the measurement window. A considerable part of the beam surface is overmodulated.

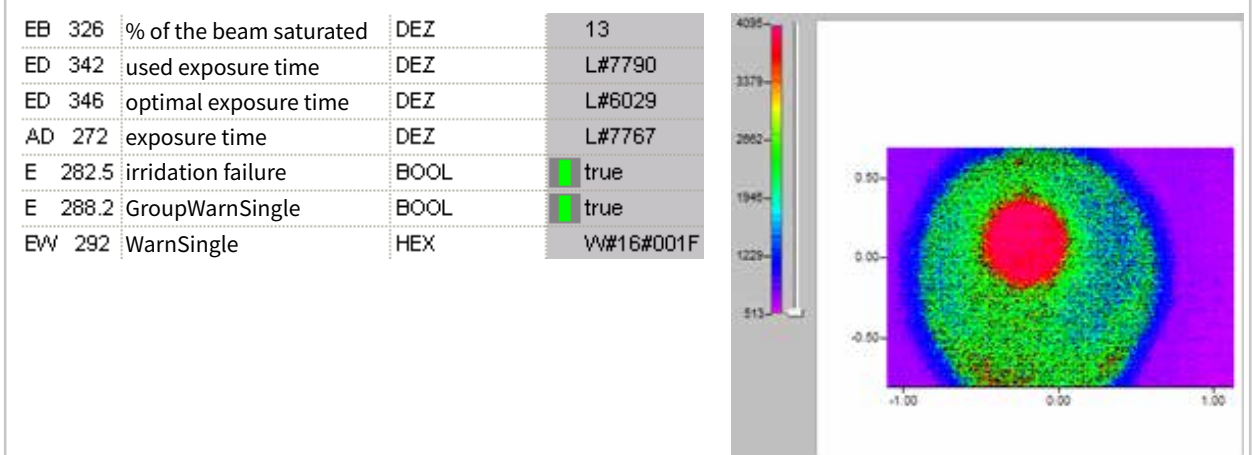

The overmodulated portion of the beam area decreases more and more in the next measurements...

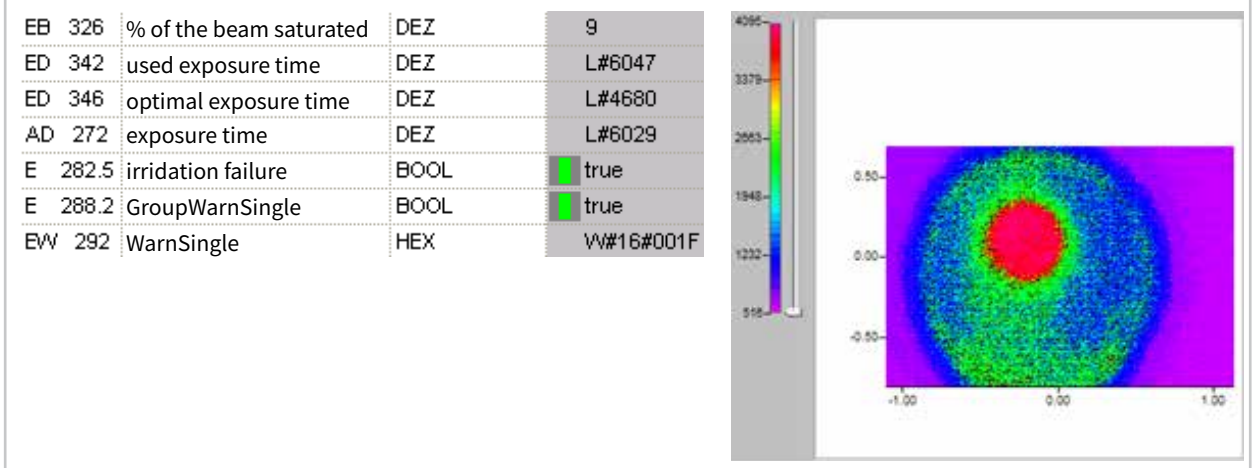

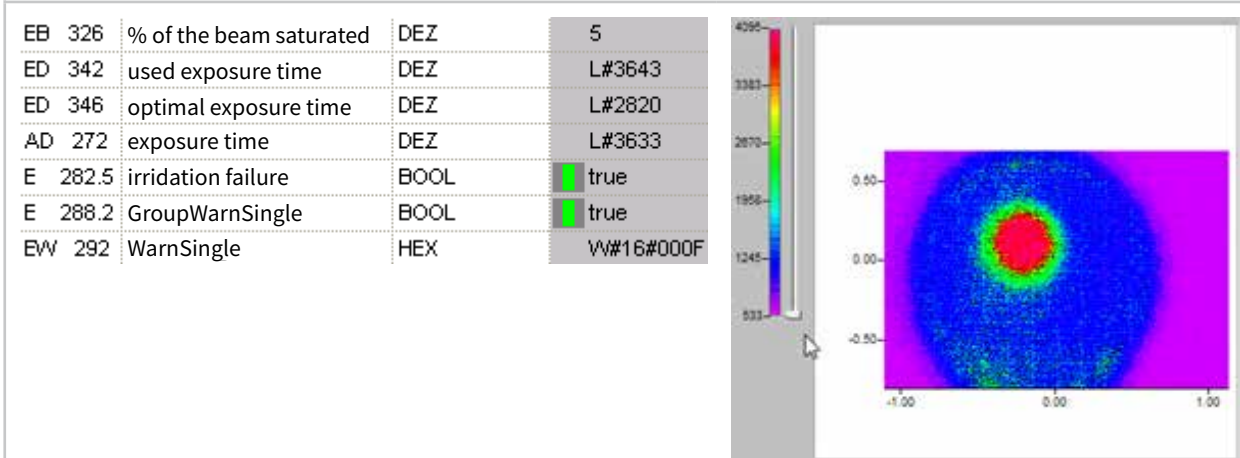
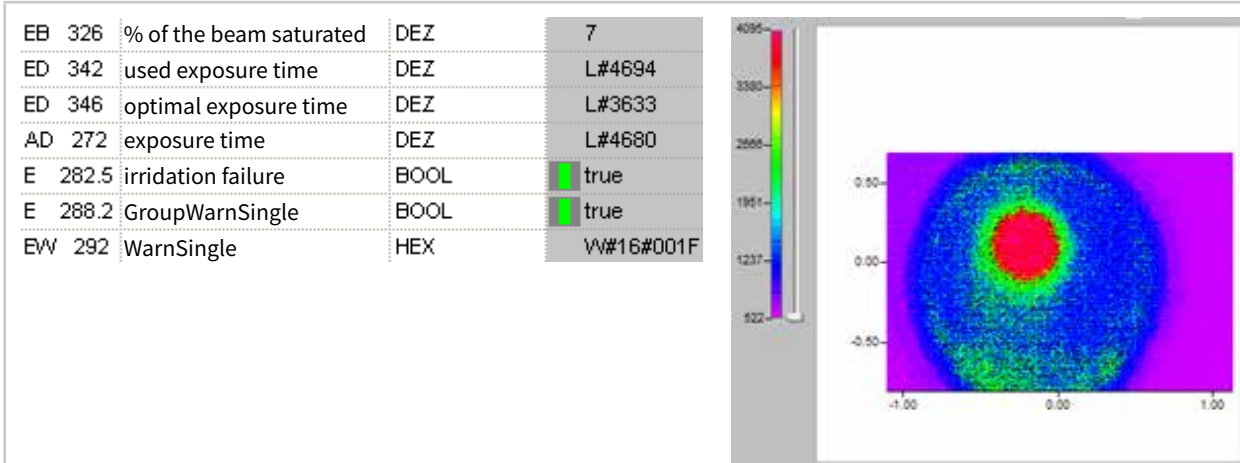

...until the limit value of overmodulation of 5% of the beam area is underrun. Thus the entry for overdriving is omitted in the warning code. The maximum level visible in the display of the measurement data is still at max. 4096 cts.

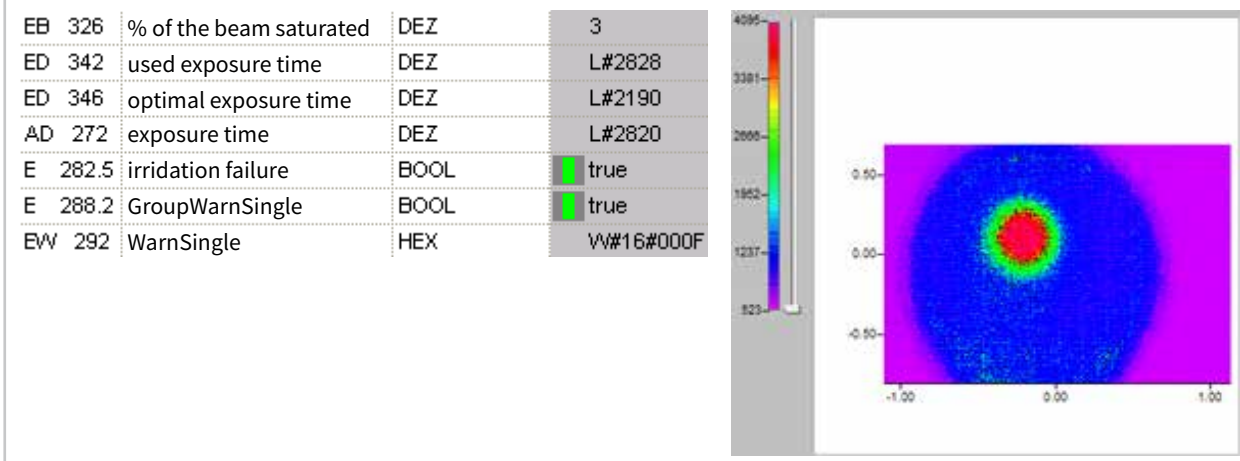

EB 326	% of the beam saturated	DEZ	1
ED 342	used exposure time	DEZ	L#2195
ED 346	optimal exposure time	DEZ	L#1700
AD 272	exposure time	DEZ	L#2190
E 282.5	irradiation failure	BOOL	true
E 288.2	GroupWarnSingle	BOOL	true
EW 292	WarnSingle	HEX	VW#16#000F

EB 326	% of the beam saturated	DEZ	0
ED 342	used exposure time	DEZ	L#1704
ED 346	optimal exposure time	DEZ	L#1320
AD 272	exposure time	DEZ	L#1700
E 282.5	irradiation failure	BOOL	true
E 288.2	GroupWarnSingle	BOOL	true
EW 292	WarnSingle	HEX	VW#16#000F

EB 326	% of the beam saturated	DEZ	0
ED 342	used exposure time	DEZ	L#1323
ED 346	optimal exposure time	DEZ	L#1026
AD 272	exposure time	DEZ	L#1320
E 282.5	irradiation failure	BOOL	true
E 288.2	GroupWarnSingle	BOOL	true
EW 292	WarnSingle	HEX	VW#16#000C

The maximum value of the measurement data is no longer at the edge of the value range. The automatic measuring window adjustment starts to cut the measuring area for better assessment.

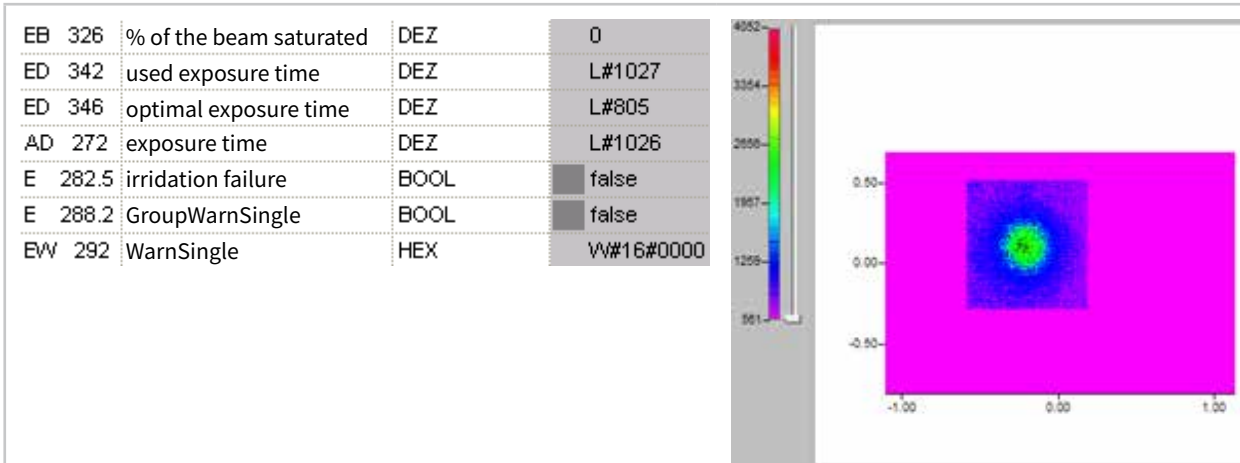

The ROI (region of interest) situated around the actual beam can now be determined correctly. The maximum value of the measurement data is not yet within the target window.

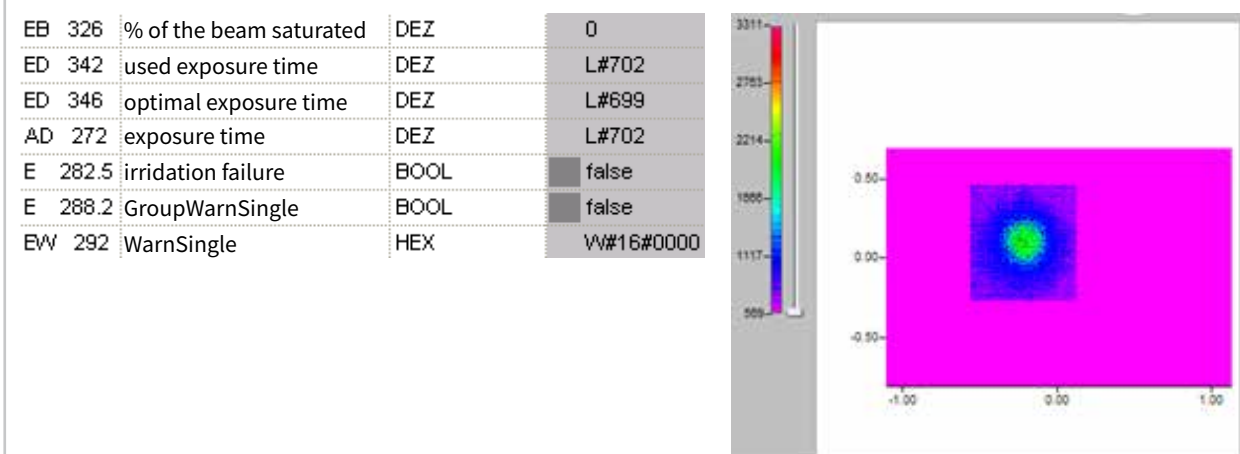
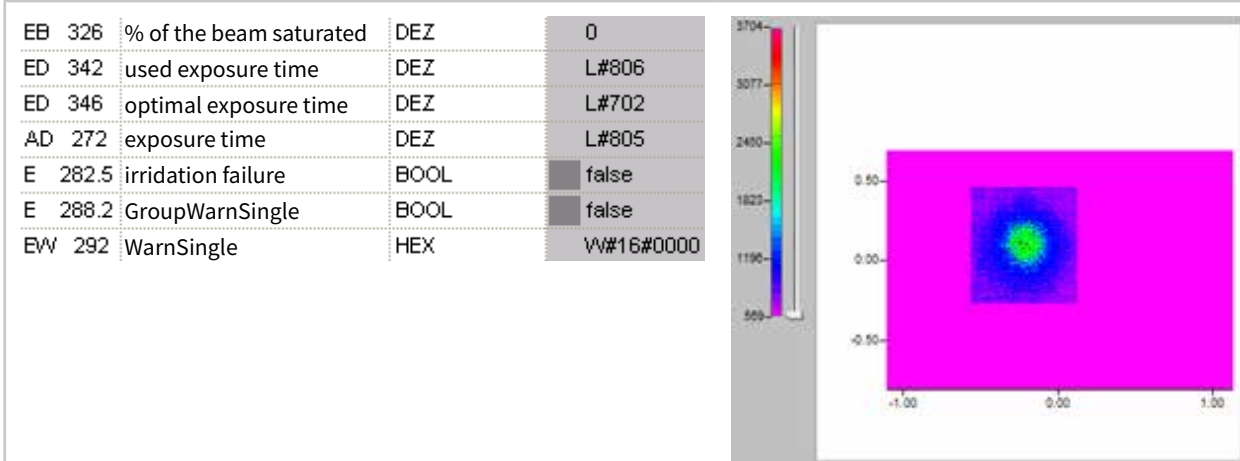

The modulation of the measurement is within the target range. Thus the optimal exposure time is very close to the one used for the last measurement.

With these steps the determination of the optimal exposure time for a laser power level and beam geometry is completed.

12 Measuring

12.1 Measuring procedure

The measuring sequences are exemplary and only describe the sequence.

Checking and ensuring compliance with the maximum energy input and the maximum absorber temperature must be supplemented and ensured by the user!

12.1.1 Measuring procedure power measurement

System (Out)	FPM (In)
Sets command.start (259.0)	
	If Shutter is open:
	Deletes status.idle (284.1)
	Sets status.acknowledge (284.6)
Deletes command.start (259.0)	
	Deletes status.acknowledge (284.6)
	Ensures readiness for operation
	Deletes status.measurement_finished (284.2)
	Sets status.ready (284.0)
Turn on the laser	
Turns off the laser (after the necessary irradiation time)	
	The irradiation carried out is identified (by means of the temperature rise of the absorber)
	Deletes status.ready (284.0)
	Sets status.measurement_running (284.1)
	Waits for thermalization (11 s)
	Optionally: detects the irradiation time
	Carries out power measurement
	Enters results into the PROFIBUS register
	Deletes status.measurement_running (284.1)
	Sets status.idle (284.4)
	Sets status.measurement_finished (284.2)
Reads out the results	

12.1.2 Measuring procedure focus measurement (untriggered)

System (Out)	FPM (In)
Sets parameters for measurement (256.0 - 256.3) or (A257.0 - 258.0 / 260 - 299)	
Sets command.start (256.4)	
	Deletes status.idle (282.4)
	Deletes status.measurement_finished (282.2)
	Deletes errorflags and -identification
	Reads parameters for the measurement (from the setup or the PROFIBUS)
	Sets status.ready_for_measurement (282.0)
	Sets status.acknowledge (282.6)
If status.ready_for_measurement == 1: turns on the laser (max. 2s)	
If laser is on and status.acknowledge == 1: Deletes command.start" (256.4)	
	Deletes status.acknowledge (282.6)
	Sets status.measurement_running (282.1)
	Starts the measurement
	When the measurement is finished: deletes status.measurement_running (282.1)
	Deletes status.ready_for_measurement (282.0)
Turns off the laser (after the necessary irradiation time)	
	Calculates parameters
	Enters parameters into PROFIBUS register or error identifiers
	Sets status.measurement_finished (282.2)
	Sets status.idle (282.4)
Reads out results/error identifiers	

12.1.3 Measuring procedure focus measurement (triggered)

System (Out)	FPM (In)
Sets parameters for the measurement (256.0 - 256.3) or (A257.0 - 258.0 / 260 - 299)	
Sets command.start (256.4)	
	Deletes status.idle (282.4)
	Deletes status.measurement_finished (282.2)
	Deletes Errorflags and -identification
	Reads parameters for the measurement (from the setup or the PROFIBUS)
	Sets status.acknowledge (282.6)
If status.acknowledge == 1: deletes command.start (256.4)	
	Deletes status.acknowledge (282.6)
	Sets status.measurement_running (282.1)
	Sets status.ready_for_measurement (282.0)
If status.ready_for_measurement==1: turns on the laser (max. 2s)	
	Laser is detected (trigger)
	Starts the measurement
	When the measurement is finished: deletes status.measurement_running (282.1)
	Deletes status.ready_for_measurement (282.0)
Turns off the laser (after the necessary irradiation time)	
	Calculates parameters
	Enters parameters into PROFIBUS register or error identifiers
	Sets status.measurement_finished (282.2)
	Sets status.idle (282.4)
Reads out results/error identifiers	

12.1.4 Measuring procedure caustic measurement

System (Out)	FPM (In)
Sets command.caustic_measurement (257.6)	
Sets parameter for caustic and for measurement (256.0; 256.3; 292; 296; 298)	
Sets command.start (256.4)	
	Deletes status.idle (282.4)
	Deletes status.measurement_finished (282.2)
	Deletes errorflags and -identification
	Reads parameters for the measurement (from the setup or the PROFIBUS)
	Sets status.caustic_measurement_running (283.0)
	Sets status.ready_for_measurement (282.0)
	Sets status.acknowledge (282.6)
If status.acknowledge == 1: deletes command.start" (256.4)	
	Deletes status.acknowledge (282.6)
	Sets status.measurement_running (282.1)
	Starts the measurement
	When the measurement is finished: deletes status.measurement_running (282.1)
	Deletes status.ready_for_measurement (282.0)
	Calculates parameters
	Enters parameters into PROFIBUS register or error identifiers
	Sets status.measurement_finished (282.2)
	Sets status.idle (282.4)
Repeat from "Sets parameter for caustic and for measurement", for all planes	
Sets command.calculate_caustic (256.5)	
	Deletes status.caustic_measurement_running (283.0)
	Carries out caustic fit, calculates beam parameter
	Enters parameters into PROFIBUS register or error identifiers
	Sets status.caustic_measurement_finished (283.1)
Reads out focus results/ error identifiers	
Deletes command.calculate_caustic (256.5)	
NOTICE! Setting and deleting command.calculate_caustic must also be performed if the caustic measurement is to be aborted (for example, because plane results are invalid).	

12.1.5 Measuring procedure combined measurement

Triggered focus and power measurement.

System (Out)	FPM (In)
Sets command.start for power module (259.0)	
	If shutter is open: (285.0)
	Power module deletes status.idle (284.4)
	Power module sets status.acknowledge (284.6)
Deletes command.start for power module (259.0)	
	Power module deletes status.acknowledge (284.6)
	Power module ensures readiness for operation
	Power module deletes status.measurement_finished (284.2)
	Power module sets status.ready (284.0)
Sets parameters for measurement with focus module (256.0 - 256.3)	
Sets command.start for focus module (256.4)	
	Focus module deletes status.idle and status.measurement_finished (282.4) (282.2)
	Focus module deletes Errorflags and -identification
	Focus module reads parameters for the measurement (from the setup or from the PROFIBUS)
	In case of a untriggered measurement: Focus module sets status.ready_for_measurement (282.0)
	Focus module sets status.acknowledge (282.6)
In case of a untriggered measurement: if status.ready_for_measurement==1: turns on laser“ (max. 2s)	
If status.acknowledge == 1 (and the laser is on in case of a untriggered measurement): deletes command.start for focus module (256.4)	
	Focus module deletes status.acknowledge (282.6)
	Focus module sets status.measurement_running (282.1)
	In case of a triggered measurement: Focus module sets status.ready_for_measurement (282.0)
„In case of a triggered measurement: if status.ready_for_measurement==1: turns on the laser“	
	In case of a triggered measurement: Laser is detected by the Focus module (trigger)
	Focus module starts measurement
	When the measurement is finished: Focus module deletes status measurement_running (282.1)
	Focus module deletes status.ready (282.0)
Turns off the laser (after the necessary irradiation time)	

System (Out)	FPM (In)
	Focus module calculates parameters
	Focus module enters parameters into PROFIBUS register or error identifiers
	Focus module sets status.measurement_finished (282.2)
	Focus module sets status.idle (282.4)
Reads out focus module results	
	Irradiation carried out is detected by the power module (temperature rise)
	Power module deletes status.ready (284.0)
	Power module sets status.measurement_running (284.1)
	Power module waits for thermalization (11 s)
	Optionally: Power module detects irradiation time
	Power module carries out power measurement
	Power module enters results into PROFIBUS register
	Power module deletes status.measurement_running (284.1)
	Power module sets status.measurement_finished (284.2)
	Power module sets status.idle (284.4)
Reads out power module results	

12.2 Timing diagrams

12.2.1 Timing diagram power measurement

As soon as the shutter is open, the device is ready for operation.

In order to initialize the measuring device for the measurement, the bit „start” has to be set in the ”Command“-byte by the external control (see Fig. 12.1).

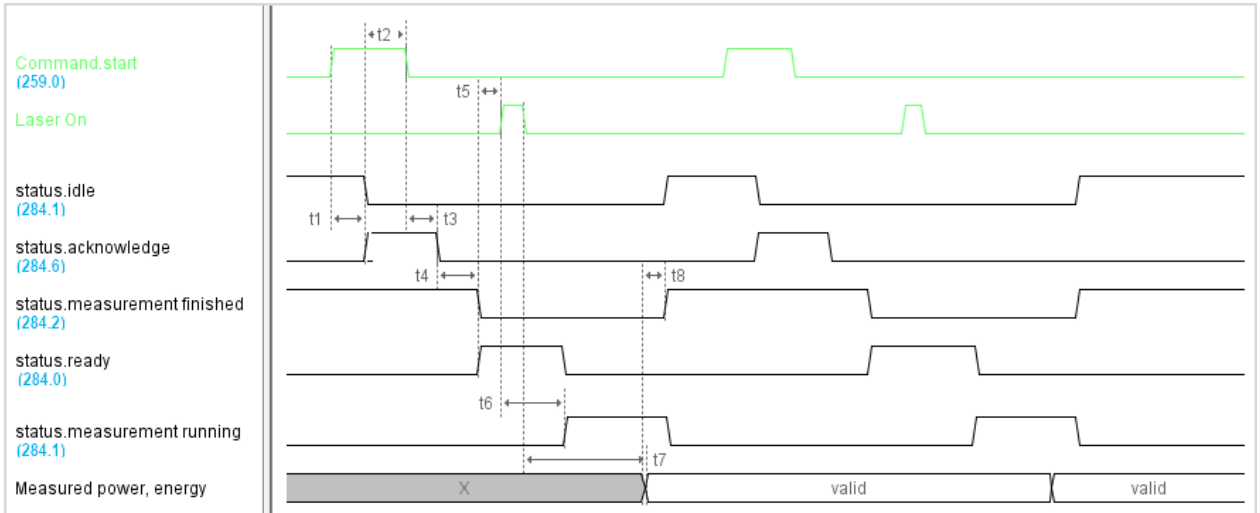

Fig. 12.1: Timing diagram power measurement

- t1: To confirm that the start command has been received, the measuring device sets the “Acknowledge” flag and deactivates “Idle”.
- t2: The command “start” must then be deleted.
- t3: Once “Start” has been deactivated again, “Acknowledge” is deactivated.
- t4: Once it is ready to measure, “Measurement Finished” is deactivated and “Ready” is set.
- t5: The laser pulse can then be triggered (shoot at the absorber for the calculated period of time or optional pulse length measurement).
- t6: After a short time, the measuring device will detect the laser pulse due to the increase in temperature of the absorber. The “Ready” is deactivated and the thermalization phase of the absorber is displayed in the status byte by the “Measurement Running” bit.
After about 1 s, the shutter can be closed again (“FPM_do_close_shutter” flag set).
- t7: After the thermalization phase ends (approx. 11 seconds), the pulse length can be determined if applicable and the measuring results (power, energy) calculated.
- t8: Once calculations are finished, the results log is populated; “Measurement Running” is deactivated, and it is set to “Measurement Finished” and “Idle”. The results can now be read out.

12.2.2 Timing diagram focus measurement (untriggered)

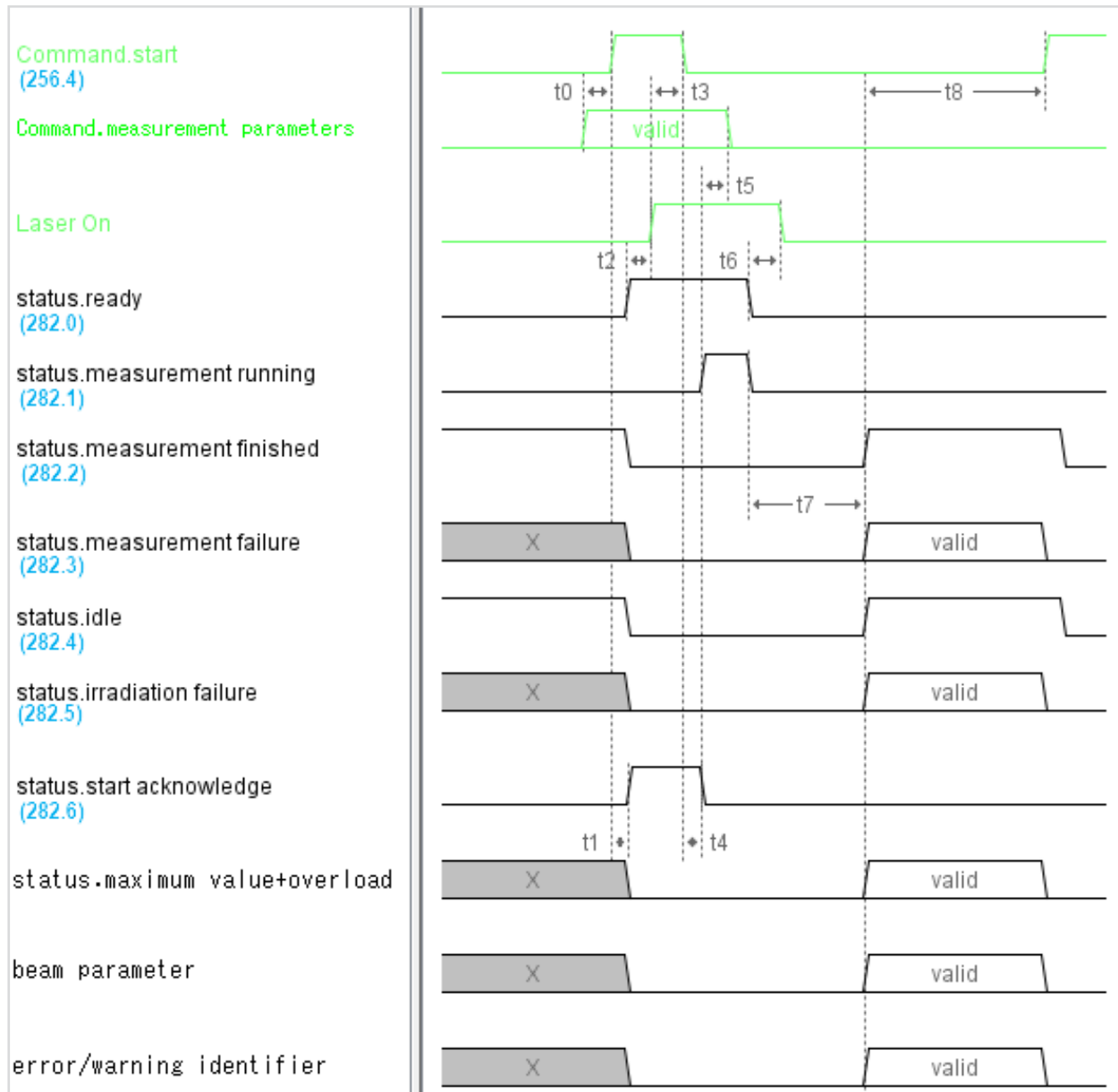

Fig. 12.2: Timing diagram focus measurement (untriggered)

- t0: The measuring parameters (setup no. or detailed measuring parameters) must be set before the “Start” flag is set.
- t1: To confirm that the start command and measuring parameters have been received, the “Start Acknowledge” flag is set and “Idle” and “Finished” deactivated. Likewise, the results log, the failure flags, and the failure identifiers are also deactivated.
For an untriggered measurement, the “Ready” flag is set at the same time to indicate that the laser can be switched on.
- t2: Once “Ready” is set, the laser pulse should be triggered “Laser On”.

- t3: Only then can the “Start” flag be deactivated, since the measurement starts after that (this only applies to untriggered measurements; with triggered measurements, “Start Acknowledge” can be acknowledged directly by deactivating “Start”).
- t4: Once “Start” has been deactivated again, “Start Acknowledge” is deactivated and “Measurement Running” set.
- t5: Once “Start Acknowledge” has been deactivated again, this means that the measuring parameters have been imported; they can then be modified as desired (e.g. in preparation for the next measurement).
- t6: Once the actual measurement has come to an end, “Measurement Running” and “Ready” are deactivated. From this point on, the laser pulse “Laser On” can be switched off, since it will not be needed for subsequent calculations.
- t7: Once calculations have been completed (or a fatal failure has occurred), the flags are set to “Finished” and “Idle”.
- If the “Measurement Failure” flag is activated, a fatal error has occurred and the measurement or calculation has been disrupted. The cause of the failure is coded in the “Error Identified” log.
- If “Measurement Failure” is not set, the measurement and calculation has been successfully performed and the results can be found in the “Beam Parameter” results log. The maximum value of the raw data and an indication of how many pixels were overloaded is coded in the high byte of the status value.
- It is possible that the “Irradiation Failure” flag has been set; in that case, a non-fatal failure has occurred (measurement overloaded or underloaded, beam on the edge of the measurement window). The cause is coded in the “Warning Identifier” log. However, the beam parameters have been determined and are available in the results registers.
- t8: Results as well as failure flags and identifiers are maintained until the next measurement is initiated by “Start”.
- t9: With a triggered measurement, the measuring process is initiated once “Start” is deactivated and continues until the point at which the device is ready to measure and is waiting to be triggered (laser detected).
- t10: “Ready” is then set to show that the laser should now be switched on, “Laser On”. The laser pulse shouldn’t have been triggered in advance, since in that case it could be gone by the time the device is ready to measure!
- t11: In this case as well, “Measurement” and “Ready” are deactivated after the end of the actual measurement. From that point on, the laser pulse “Laser On” can be switched off.

12.2.3 Timing diagram focus measurement (triggered)

The following timing diagram shows a triggered measurement. This is the standard case.

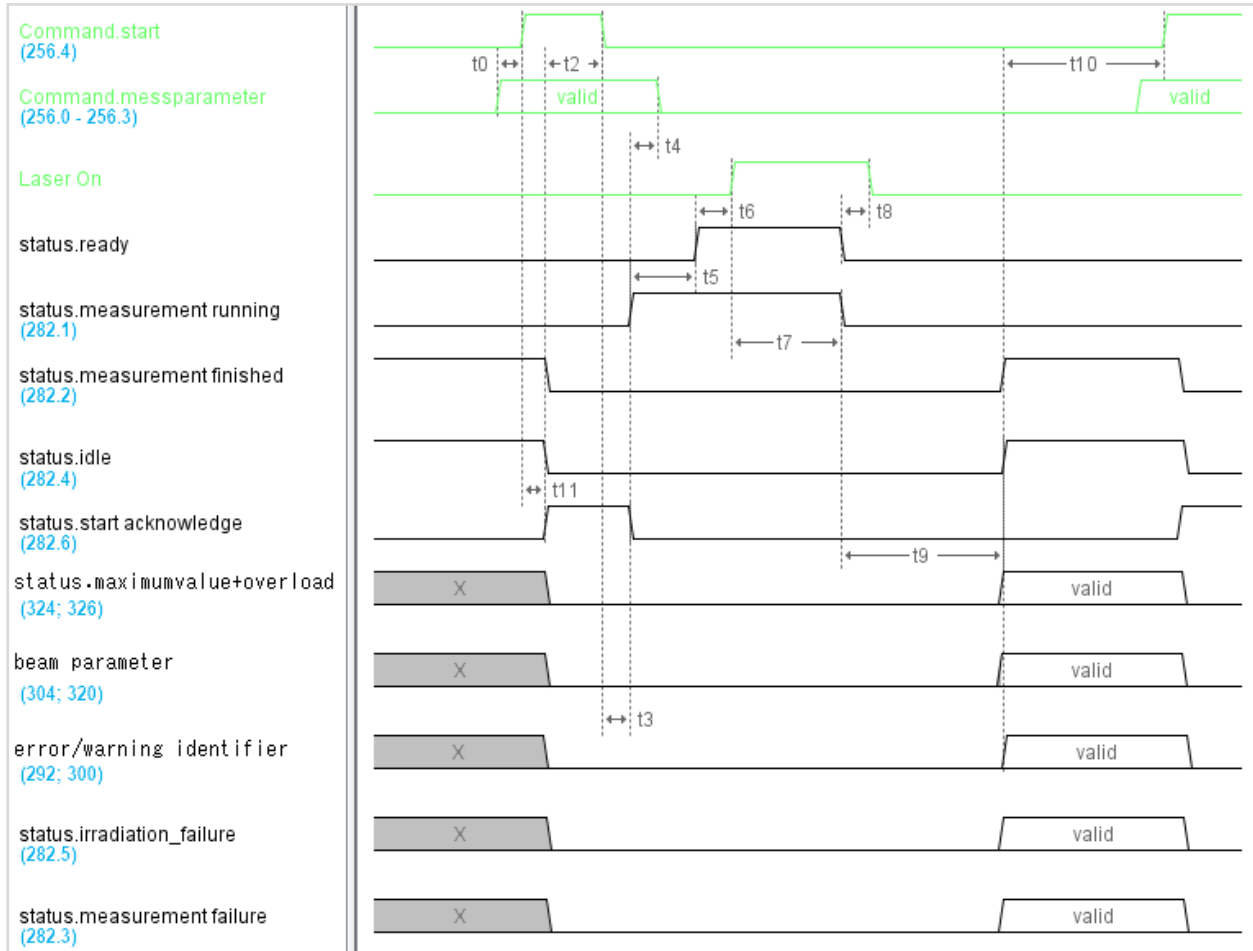

Fig. 12.3: Timing diagram focus measurement (triggered)

- t0: The measuring parameters (setup no. or detailed measuring parameters) must be set before the “Start” flag is set.
- t1: To confirm that the start command and measuring parameters have been received, the “Start Acknowledge” flag is set and “Idle” and “Finished” deactivated. Likewise, the results log, the failure flags, and the failure identifiers are also deactivated.
- t2: Then the “Start” flag can be deactivated.
- t3: Once “Start” has been deactivated again, “Start Acknowledge” is deactivated and “Measurement Running” set.
- t4: Once “Start Acknowledge” has been deactivated again, this means that the measuring parameters have been imported; they can then be modified as desired (e.g. in preparation for the next measurement).
- t5: Once it is ready to measure, it is set to “Ready”. “Laser On” indicates that the laser should now be switched on. The laser pulse shouldn’t have been triggered in advance, since in that case it could be gone by the time the device is ready to measure!

- t6: The laser pulse triggers the actual measurement.
- t7: Once this has come to an end, “Measurement Running” and “Ready” are deactivated.
- t8: From this point on, the laser pulse “Laser On” can be switched off, since it will not be needed for subsequent calculations.
- t9: Once calculations have been completed (or a fatal failure has occurred), the flags are set to “Finished” and “Idle”.
- If the “Measurement Failure” flag is activated, a fatal error has occurred and the measurement or calculation has been disrupted. The cause of the failure is coded in the “Error Identified” log.
- If “Measurement Failure” is not set, the measurement and calculation has been successfully performed and the results can be found in the “Beam Parameter” results log. The maximum value of the raw data and an indication of how many pixels were overloaded is coded in the high byte of the status value.
- It is possible that the “Irradiation Failure” flag has been set; in that case, a non-fatal failure has occurred (measurement overloaded or underloaded, beam on the edge of the measurement window). The cause is coded in the “Warning Identifier” log. However, the beam parameters have been determined and are available in the results registers.
- t10: Results as well as failure flags and identifiers are maintained until the next measurement is initiated by “Start”.

12.2.4 Timing diagram caustic measurement

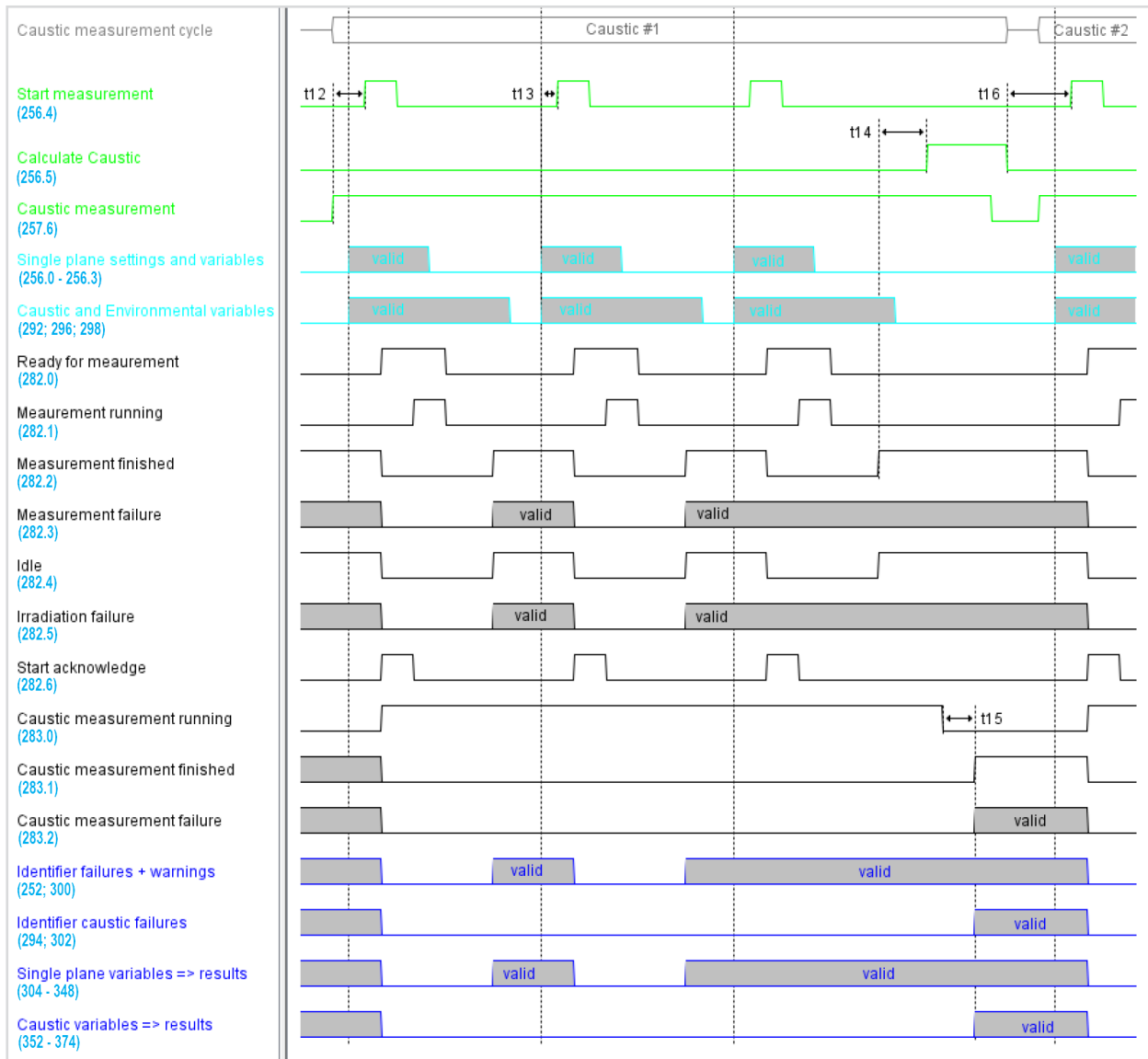

Fig. 12.4: Timing diagram caustic measurement

- t12: Before the start of the first single plane measurement, “Caustic Measurement” must be set and then only deactivated once “Caustic Measurement Finished” has been set. If several caustics are to be measured in succession, the flag can also remain permanently set.
- t13: The caustic variables (plane index and Z position) must be set just like the single plane variables before the “Start Measurement” flag is set. This applies to every single measurement plane. The parameters should be deleted only once “Start Acknowledge” has been deactivated again, and the Environmental variable should even be retained until “Measurement Finished” is set. As soon as the caustic variables have been imported, “Caustic Measurement Running” is set.
- t14: When the last single plane has been measured and the corresponding calculations have been performed („Measurement finished“ set), „Calculate Caustic“ can be set. “Caustic Measurement Running” will then be deactivated.

- t15: Once the caustic fit and calculation of the beam parameters have been performed, “Caustic Measurement Finished” is set. Then the results (“Caustic Variables”) will also be available. If errors occur, “Caustic Measurement Failure” is set, the cause of the failure is coded in the logs identifier for caustic measurement errors/warnings.
- t16: “Calculate Caustic” **must** be deactivated before the next caustic measurement (meaning “Caustic Measurement” is set) can be initiated.

When completing a caustic measurement, “Calculate Caustic” must be set, even in case of error, and then deactivated again so that a new caustic measurement can be initiated.

12.2.5 Timing diagram combined measurement

Triggered focus and power measurement.

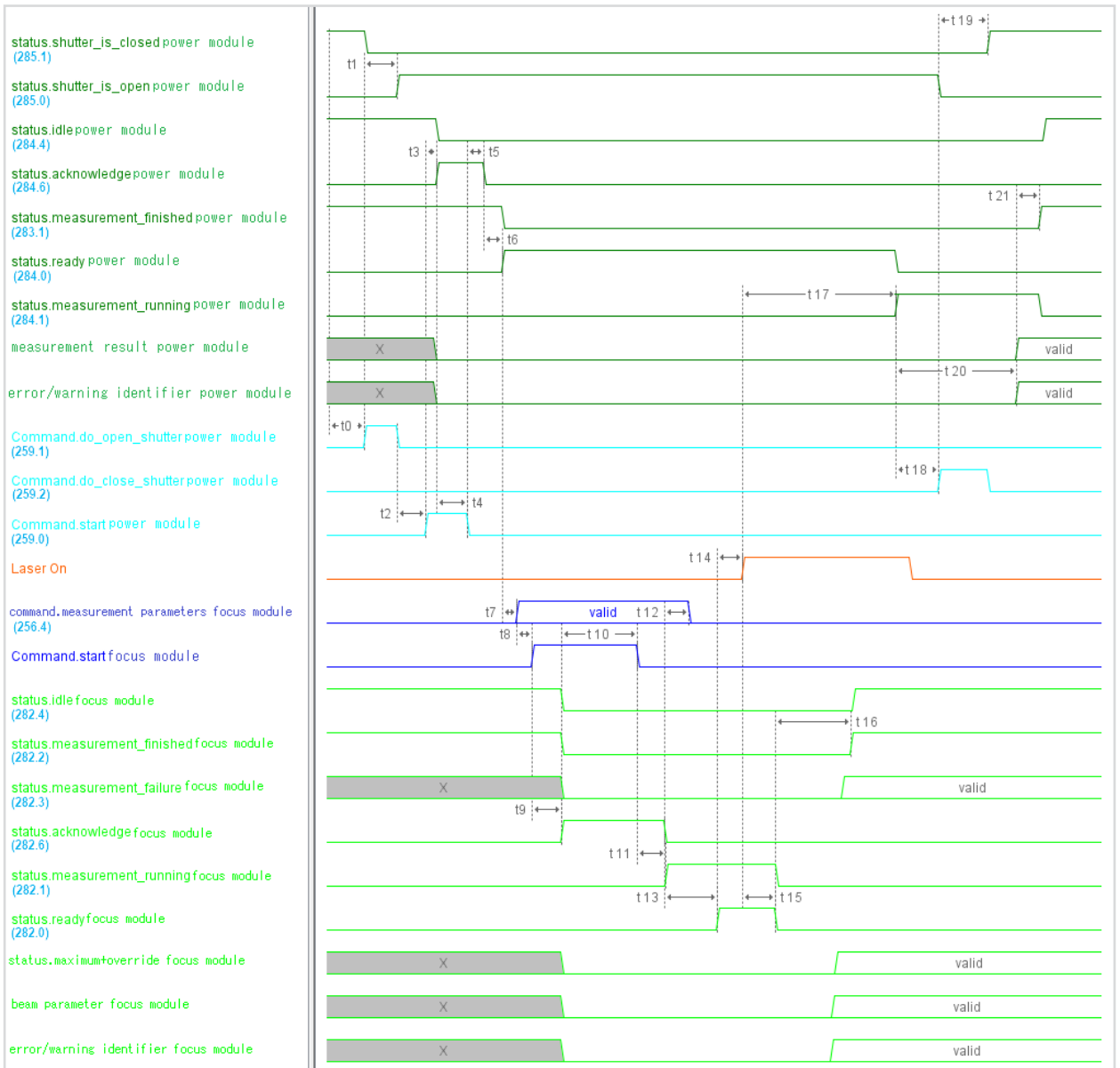

Fig. 12.5: Timing diagram combined measurement

- t0: If the shutter is closed, opening must be triggered by setting the “do_open_shutter” bit in the FPM command byte.
- t1: If the “shutter_is_open” flag is set in the FPM status word (status of the power module), this has happened and the device is ready for measurement. “Do_open_shutter” can then be deleted.
- t2: To initialize the measurement, the “start” bit must be set in the FPM command byte.
- t3: As confirmation that the start command has been received, the measuring device sets the flag in the FPM status word “acknowledge” and “idle” is deleted.
- t4: The “start” command in the FPM command byte must then be deleted.
- t5: When “start” has been deleted again, “acknowledge” is deleted.
- t6: When the device is ready for measurement, “measurement finished” in the FPM status word is deleted and “ready” is set.

The focus module is now addressed. The command bits and status flags described below are those contained in the focus module part (not FPM).

- t7: The measurement parameters (Setup No. or detailed measurement parameter) must be set before the “start” flag is set.
- t8: By analogy with the handshake at the start of power measurement, the “start” bit is then set in the command field for initialization.
- t9: As confirmation that the start command and the measurement parameters have been received, the “acknowledge” flag is set, “idle” and “finished” are deleted. The results registers, error flags and error identifiers are also deleted.
- t10: The “start” flag may then be deleted.
- t11: When “start” has been deleted again, “acknowledge” is deleted and “measurement running” is set.
- t12: When “acknowledge” has been deleted again, this confirms that the measurement parameters have been read in; they can then be changed as required (e.g. In preparation for the next measurement).
- t13: When the device is ready for measurement, “ready” is set as a signal that the laser should now be switched on.
- t15: When this has been completed, “measurement running” and “ready” are deleted.

- t16: When the calculations have been completed (or a fatal error has occurred), the flags “finished” and “idle” are set.
- If the “measurement failure” flag is set, a fatal error has occurred and the measurement or calculation was aborted. The cause of the error is encoded in the register “Error identifier”.
- If “measurement failure” is not set, the measurement and calculation was carried out successfully and the results can be found in the “beam parameter” results registers. The maximum value of the raw data and an indication of how many pixels were overridden is encoded in the high byte of the status word.
- The flag “irradiation failure” may be set; in this case, a non-fatal error has occurred (measurement signal level too high or too low, beam lies at the edge of the measurement window). The cause is encoded in the register “Warning identifier”. However, the beam parameters have been determined and are available in the results registers.

The power measurement is also carried out during the beam parameter measurement and calculation.

- t17: After a short laser-on time, the power module recognizes the laser pulse by the temperature increase of the absorber. The “ready” flag in the FPM status word is deleted and the thermalization phase of the absorber is indicated by “measurement running”.
- t18: After approx. 1 s, when the laser has been switched off again, the shutter can also be closed again (set flag “FPM_do_close_shutter”).
- t19: When the “shutter_is_closed” flag is set in the FPM status word, this has happened. “FPM_do_close_shutter” can then be deleted.
- t20: After the end of the thermalization phase (approx. 11 seconds), the pulse duration may be determined and the measurement results (power, energy) are calculated.
- t21: When the calculations have been completed, the results are written to the results register of the power measurement. In the FPM status word, “measurement running” is deleted, “measurement finished” and “idle” are set. The results can now be read out.

Results, error flags and identifiers are retained until the next measurement is initiated.

12.3 Flow chart combined measurement

Triggered focus and power measurement.

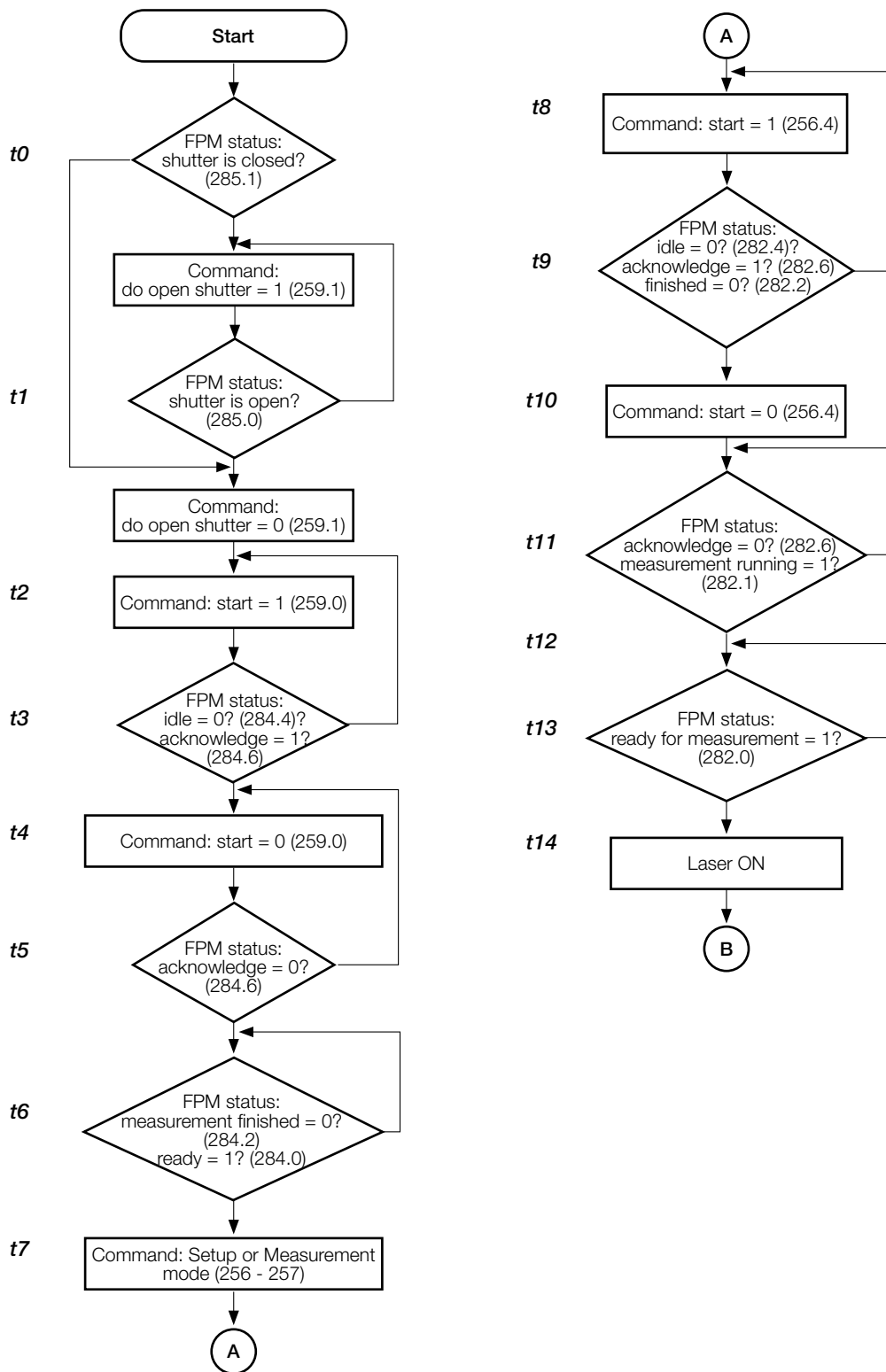

Fig. 12.6: Flow chart combined measurement

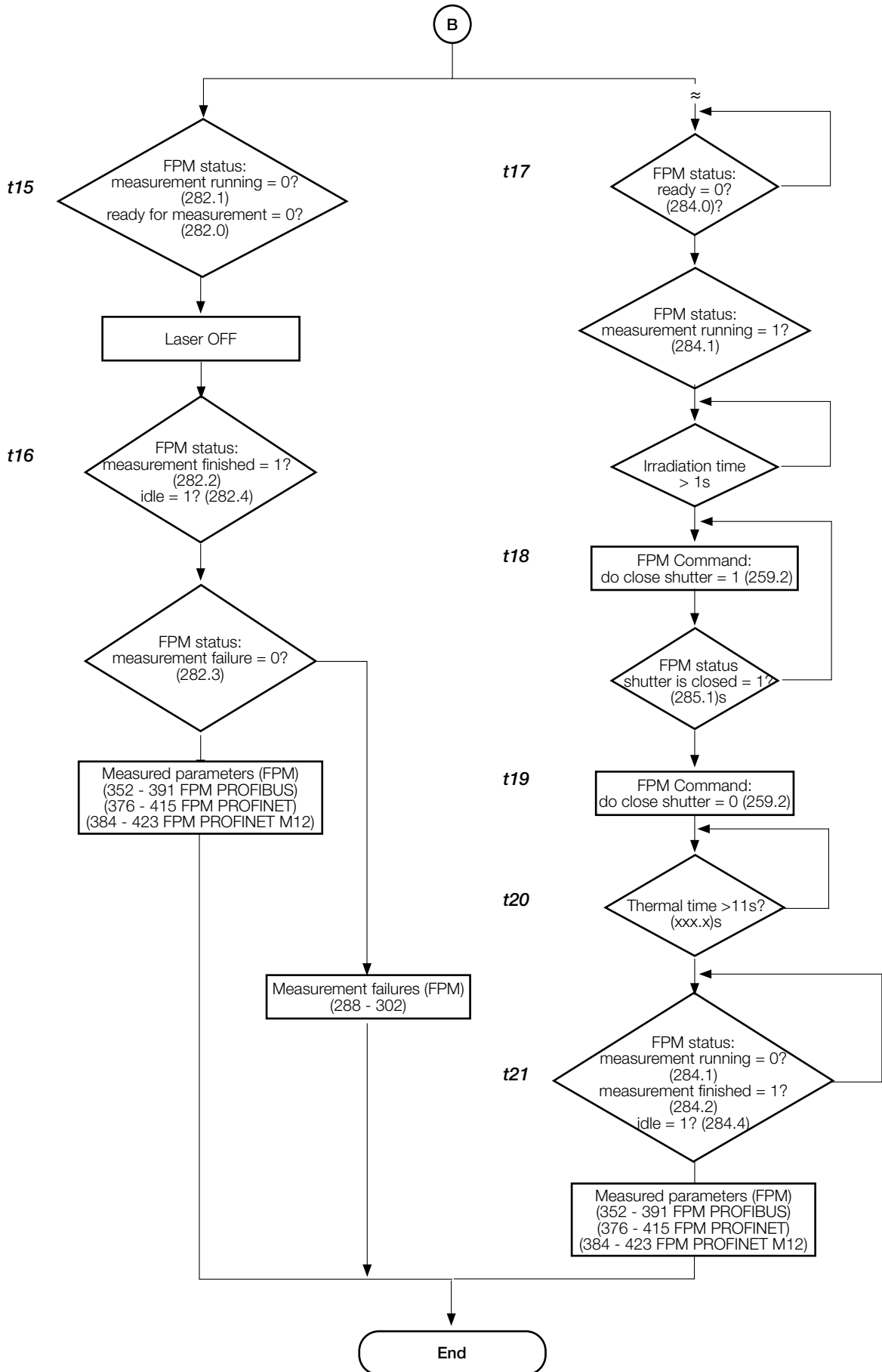

Fig. 12.7: Flow chart combined measurement

13 Display of a measurement in the web browser

The FPM has a web interface. This can be used to display a measurement as a HTML page.



For the FPM with PROFIBUS or PROFINET, the Ethernet port may be located under the cover of the maintenance hatch. Remove the cover of the maintenance hatch on the connection side of the device.

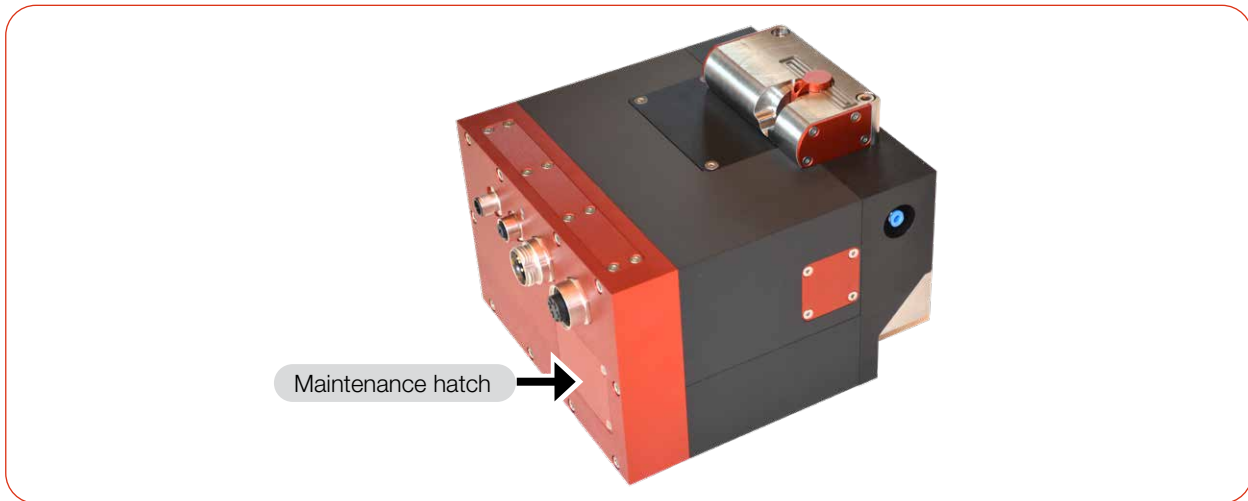

Fig. 13.1: Maintenance hatch on the FPM

1. Connect the FPM to the network using an RJ45 cable.
2. Make sure that the FPM and the PC are on the same network. If DHCP is already set up in the network, an IP address is assigned to the FPM. If this is not the case, then the IP address of the PC must be changed. The IP address of the FPM is on its identification plate.
3. Open the web browser on the PC and enter the IP address of the FPM.

After a measurement, the single planes that have been measured are shown. It will display the power density distribution as a 2D display and the measuring values in tabular form.

If a caustic has been measured, this is also presented in 2D. The calculated values are shown in tabular form. The last single plane of the caustic to be measured is also shown with the corresponding measuring values (see Fig. 13.2).

The values of a caustic measurement remain stored until a new caustic measurement is carried out or the device is switched off.

Save the website with any of the most common browsers (except Edge) for documentation purposes.

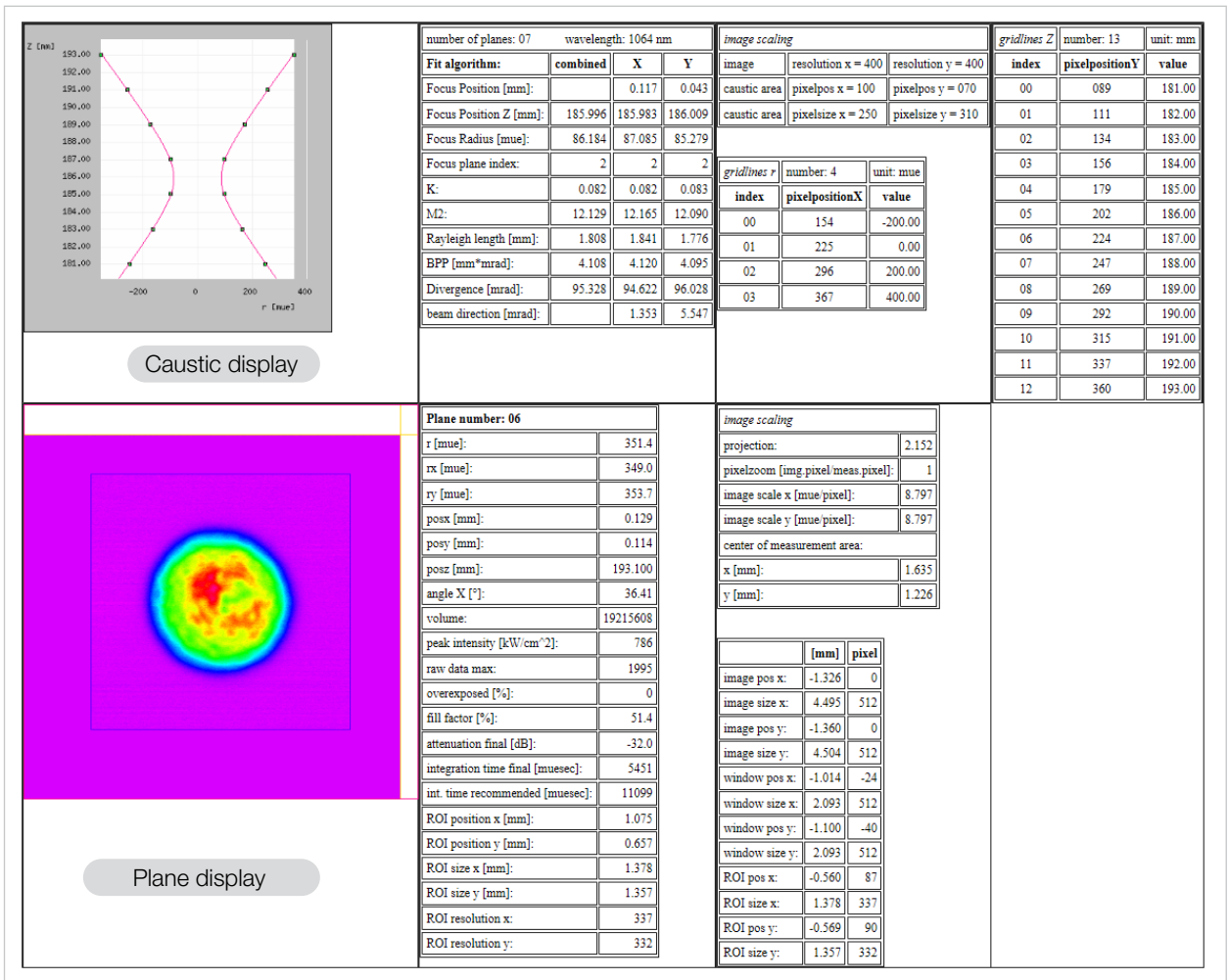

Fig. 13.2: Example for presentation of a caustic measurement in the web browser

14 Maintenance and service

14.1 Maintenance intervals

The operator is responsible for determining the maintenance intervals of the measuring device.

PRIMES recommends a maintenance interval of 12 months for inspection, validation and calibration.

If the device is used sporadically (less than once a day), the maintenance interval can be extended up to 24 months.

Please note that the safety and warning functions of the device must be checked regularly.

14.2 Cleaning

14.2.1 Cleaning the device surface

1. Close all device openings.
2. Clean the device surface with clean and oil-free compressed air.
3. For further cleaning, use a mixture of distilled water and isopropanol in a ratio of approx. 5:1. Use lint-free cleaning cloths that do not cause scratches.
4. If these steps are not sufficient, please contact PRIMES or your PRIMES distributor.

14.2.2 Cleaning the protective window

1. After a measurement, let the device cool down for an adequate period of time.
2. Remove the protective window according to chapter 14.4.2 on page 84.
3. Clean the protective window with clean and oil-free compressed air.
4. For further cleaning, use isopropanol (observe the manufacturer's safety instructions). The coating of the protective window is particularly sensitive to scratches. Use cloths suitable for cleaning protective windows.
5. Replace the protective window with a new one if the contamination cannot be removed or if it is damaged.
6. Mount the protective window according to chapter 14.4.2 on page 84.

14.3 Spare parts

The following spare parts are available for the FPM:

Article	Order Number
Protective window cartridge	825-010-002
Protective window (diameter 15 mm; thickness (1,5 mm)	825-010-006
Maintenance hatch with Ethernet port	825-010-007

14.4 Maintenance of the protective window

To protect against contamination, the FPM is supplied with a protective window in the beam path. The protective window is a wear part and can be replaced if necessary.

Slight soiling of the protective window can be carefully removed when cooled down. In case of heavy, non-removable contamination or damage, the protective window must be replaced with a new one. Either only the protective window or the protective window cartridge including the protective window can be replaced.



The protective window is coated with an anti-reflection coating and has low reflection values of less than 1%. To avoid increased reflection values, use only original PRIMES protective windows.



CAUTION

Burns due to hot components

The protective window is hot after a measurement.

- ▶ Do not clean or change the protective window/protective window cartridge directly after a measurement.
- ▶ Let the device cool down for an adequate period of time. The cooling time varies depending on the laser power and the irradiation time.

NOTICE

Damage/destruction of the device

Contamination and fingerprints on the protective window can cause damage or cracking/splintering of the protective window during measuring operation.

- ▶ Only clean or change the protective window in a dust-free environment.
- ▶ Do not touch the protective window with bare hands.
- ▶ When exchanging the protective window, wear suitable gloves.

14.4.1 Exchange of the protective window cartridge

The protective window is inside an exchangeable cartridge, which can be exchanged fast and without any tools.

1. Please observe the safety instructions in chapter 1 „Basic safety notes“ on page 7.
2. Switch off the laser and secure it against unintentional restart.
3. Let the device cool down.
4. Make sure that all moving parts, e.g. robot arms, etc. are at a standstill and that they cannot be moved unintentionally.
5. Turn the cartridge shutter by 90° in order to unlock it.
6. Open the cartridge and take it out of the housing.
7. Put in the new cartridge.
8. Close the cartridge and lock by turning it by 90° (the shutter locks into place audibly).



Fig. 14.1: Protective window inside the exchangeable cartridge

14.4.2 Exchanging or cleaning of the protective window

The protective window in the exchangeable cartridge is an wear part, which can be exchanged when necessary.

The exchangeable cartridge can be disassembled for cleaning or replacing the protective window:

1. Remove the exchangeable cartridge as described in chapter 14.4.1 on page 83.
2. The protective window is held in the cartridge by 4 magnets and the cover plate. Lift the cover plate against the magnetic attraction out of the exchangeable cartridge or push it aside.
3. Replace and/or clean the protective window.
4. When reassembling, make sure the cover plate is flush with the side of the exchangeable cartridge.

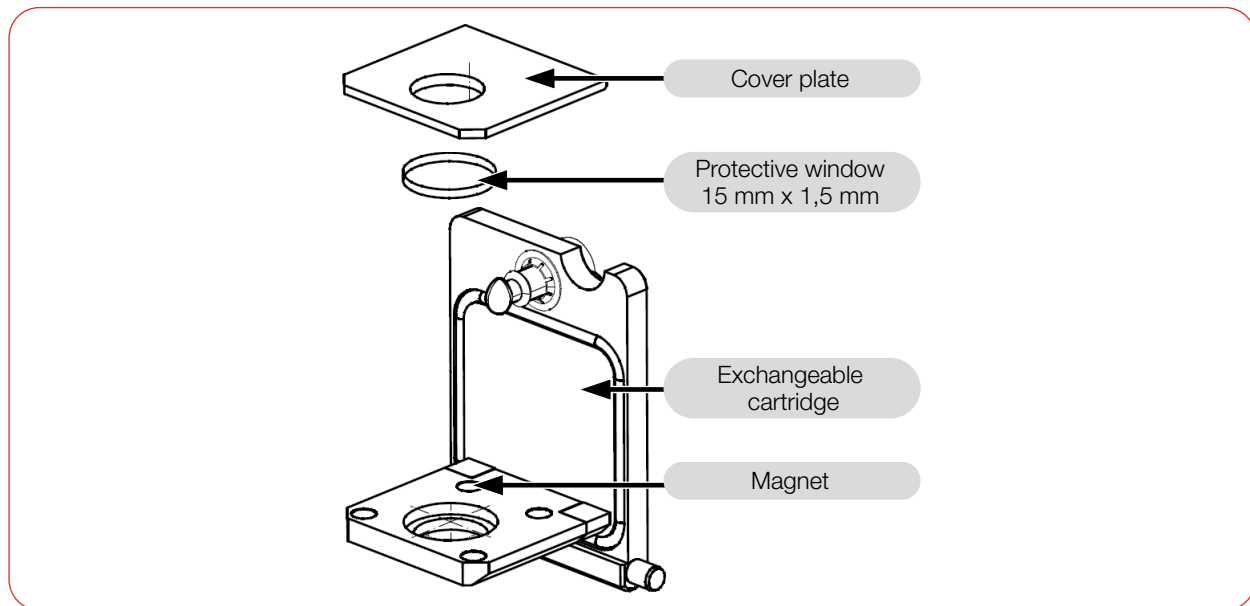

Fig. 14.2: Exploded view of exchangeable cartridge

15 Measures for the product disposal

As a B2B device, this PRIMES measuring device is subject to the European Waste Electrical and Electronic Equipment (WEEE) Directive and the corresponding national laws. The WEEE directive obliges the operating company to dispose of the device in an environmentally sound manner, not with household waste, but in a separate WEEE collection.

PRIMES gives the opportunity to return PRIMES measuring devices for free disposal within the scope of the Waste of Electrical and Electronic Equipment (WEEE Directive). This service does not include shipping costs. Send PRIMES measuring devices to be disposed of within the EU to our address:

PRIMES GmbH
Max-Planck-Str. 2
64319 Pfungstadt
Germany

If you are located outside the EU, please contact your local PRIMES distributor to discuss the disposal procedure for your PRIMES measuring device.

PRIMES is registered at the German „joint body“ for producers „Stiftung Elektro-Altgeräte Register“ (Stiftung EAR). Our number is: WEEE-reg.-no. DE65549202.

16 Declaration of incorporation for partly completed machinery

Original Declaration of Incorporation of Partly Completed Machinery

according to the Machinery Directive 2006/42/EC, Annex II B

The manufacturer: PRIMES GmbH, Max-Planck-Straße 2, 64319 Pfungstadt, Germany
hereby declares, that the partly completed machine with the designation:

FocusParameterMonitor (FPM)

Types: FPM 60; FPM 100; FPM 120; FPM 160

is in conformity with the following relevant EC Directives:

- Machinery Directive 2006/42/EC
- EMC Directive EMC 2014/30/EU
- Directive 2011/65/EC on the restriction of the use of certain hazardous substances (RoHS) in electrical and electronic equipment

Authorized for the documentation:

PRIMES GmbH, Max-Planck-Str. 2, 64319 Pfungstadt, Germany

The technical documentation according to Annex VII Part B of the Machinery Directive which belongs to the partly completed machinery was drawn up. The manufacturer obligates himself to provide the national authority in charge with technical documents in response to a duly substantiated request within an adequate period of time.

This partly completed machinery is intended for the integration into a laser system. An initial operation is strictly prohibited until it was ensured that the complete machine, into which the partly completed machinery was integrated, is in compliance with the requirements of the EC-Directive 2006/42/EC as well as the Laser Safety, e.g. the DIN EN ISO 12254, the DIN EN 60825 and TROS.

Pfungstadt, November 10, 2023



Dr. Reinhard Kramer, CEO

Declaration of Incorporation

according to the Supply of Machinery (Safety) Regulations 2008

The manufacturer: PRIMES GmbH, Max-Planck-Straße 2, 64319 Pfungstadt, Germany hereby declares, that the partly completed machine with the designation:

FocusParameterMonitor (FPM)

Types: FPM 60; FPM 100; FPM 120; FPM 160

is in conformity with the following relevant UK regulations:

- Supply of Machinery (Safety) Regulations 2008
- Electromagnetic Compatibility Regulations 2016
- Directive 2011/65/EC on the restriction of the use of certain hazardous substances (RoHS) in electrical and electronic equipment

Authorized for the documentation:

PRIMES GmbH, Max-Planck-Str. 2, 64319 Pfungstadt, Germany

The technical documentation according to Annex VII Part B of the Machinery Directive which belongs to the partly completed machinery was drawn up. The manufacturer obligates himself to provide the national authority in charge with technical documents in response to a duly substantiated request within an adequate period of time.

This partly completed machinery is intended for the integration into a laser system. An initial operation is strictly prohibited until it was ensured that the complete machine, into which the partly completed machinery was integrated, is in compliance with the requirements of the EC-Directive 2006/42/EC as well as the Laser Safety, e.g. the DIN EN ISO 12254, the DIN EN 60825 and TROS.

Pfungstadt, November 10, 2023



Dr. Reinhard Kramer, CEO

17 Technical data

Measurement parameters	FPM 60	FPM 100	FPM 120	FPM 160
Beam dimensions (increased measurement uncertainty)	350 - 2 000 μm (150 - 350 μm)	75 - 450 μm (40 - 75 μm)	300 - 1 800 μm (150 - 300 μm)	125 - 800 μm (80 - 125 μm)
Wavelength range (see identification plate)	1 030 - 1 090 nm	1 030 - 1 090 nm	1 030 - 1 090 nm	1 030 - 1 090 nm or 515 - 532 nm
Distance measuring plane to entrance plane (inside the device)	0.2 mm	0.5 mm	25 mm	30 mm
Max. laser power	8 kW			
Max. centered tolerance	± 1 mm	± 0.1 mm	± 0.5 mm	± 0.2 mm
Max. angle of incidence perpendicular to inlet aperture	± 5 mrad	± 5 mrad	± 5 mrad	± 5 mrad
$E_{\text{Min}}/E_{\text{Max}}$ per measuring cycle (depending on absorber temperature)	120 J/3 000 J			
Max. beam divergence	60 mrad	100 mrad	120 mrad	160 mrad
Max. power density (60 mm below entrance opening)	1 MW/cm ²			
Max. spot diameter at entrance opening	2 mm			
Focus position within the device, maximum	15 mm	15 mm	40 mm	45 mm
Laser pulse duration	0.3 - 1 s			
Supply data				
Power supply, DC	24 V \pm 5 %, max. 0.5 A (supplied by sensor)			
Connector types of the power supply	PROFIBUS: M18 7/8" PROFINET: AIDA-compatible PROFINET M12: M12-SPEEDCON L-coded			
Compressed air specification according to ISO 8573-1: 2010	[1:4:2]			
Flow rate	10 - 15 l/min			
Min./max. pressure	1 bar/2 bar			
Communication				
PROFIBUS	Plug/socket 5-pole; M12-SPEEDCON; B-coded			
PROFINET	AIDA-compatible RJ45 connector			
PROFINET M12	Plug/socket 4-pole; M12-SPEEDCON; D-coded			
Ethernet (PROFIBUS, PROFINET)	RJ45 connector			
Ethernet (PROFINET M12)	M12-SPEEDCON X-coded			

Dimensions and weight	
Dimensions (L x W x H) (without cables and plugs)	210 x 185 x 153 mm
Weight (approx.)	10 kg
Protection	
IP code (with closed shutter)	IP64
Protection class	III
Environmental conditions	
Operating temperature range	15 – 40 °C
Storage temperature range	5 – 50 °C
Reference temperature	22 °C
Permissible relative humidity (non-condensing)	10 – 80 %

18 Dimensions

All dimensions in millimeters (mm) unless otherwise specified.

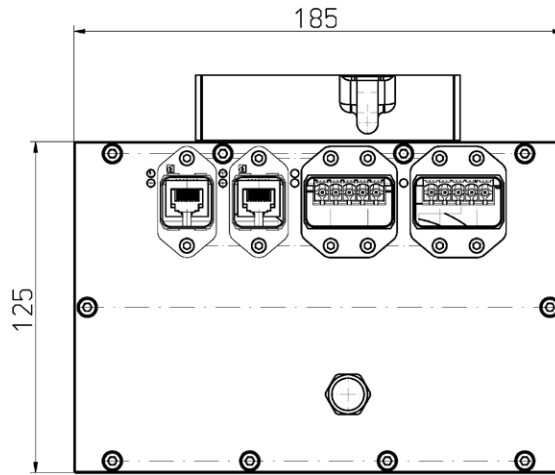

Front view

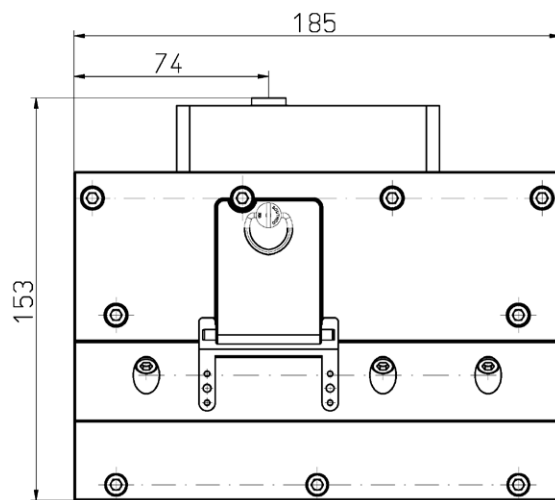

Rear view

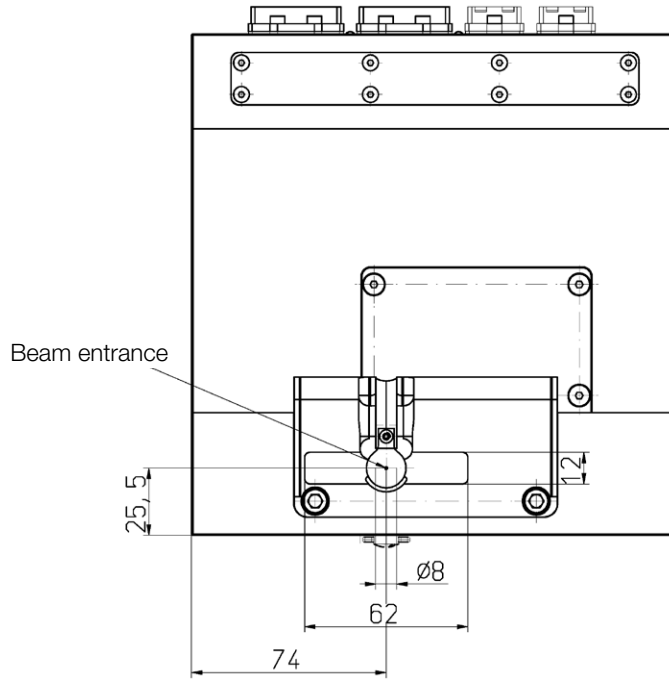

Top view

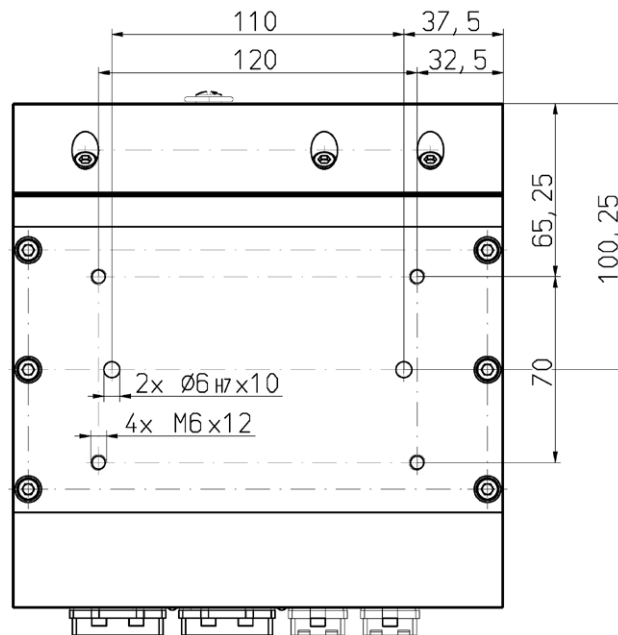

Bottom view

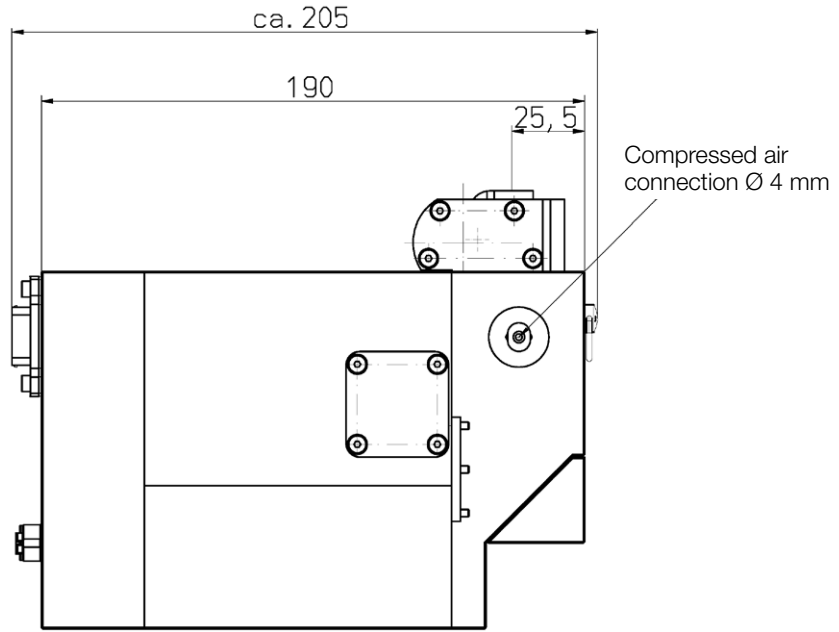

Side view right

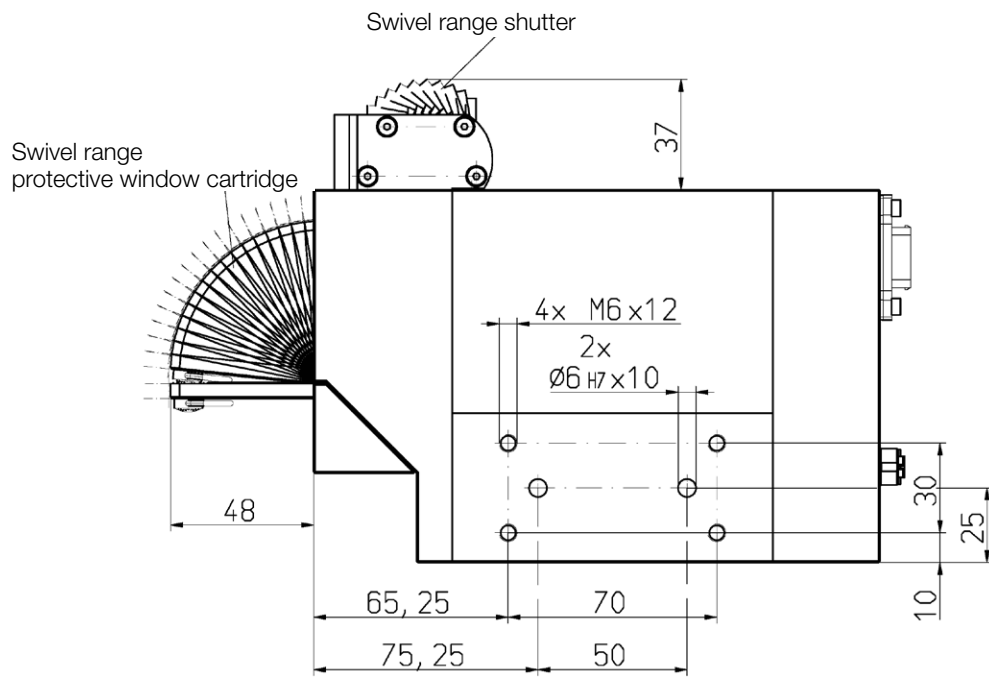

Side view left