

Preparations for the efficient performance of measurements by PRIMES



MicroSpotMonitor MSM+ HB10

PRIMES - the company

PRIMES is a manufacturer of measuring devices which are used to analyze laser beams. These devices are employed for the diagnostics of high-power lasers ranging from CO₂-, fiber- and solid-state lasers to diode lasers. A wavelength range from infrared through to near UV is covered, offering a wide variety of measuring devices to determine the following beam parameters:

- Laser power
- Beam dimensions and position of an unfocused beam
- Beam dimensions and position of a focused beam
- Beam quality factor M²

Development, production and calibration of the measuring devices is performed at PRIMES. This guarantees optimum quality, excellent service, and a short reaction time, providing the basis for us to meet all of our customers' requirements quickly and reliably.



PRIMES GmbH
Max-Planck-Str. 2
64319 Pfungstadt
Germany

Tel +49 6157 9878-0
info@primes.de
www.primes.de

1 Safety is important to us

1.1 Personal protection equipment

In order to ensure the health of our employees, wearing personal protective equipment (PPE) is essential for many activities. Therefore, please inform us whether and what kind of personal protective equipment is required in your company.

1.2 Laser protection and safety regulations

In order to perform safe measurements, the place of operation must comply with the current laser protection and safety regulations. Please understand that we cannot perform the measurements if the safety precautions on site are inadequate.

2 Structural conditions

2.1 Safety Interlock

The safety interlock protects in the event of a fault by automatically switching off the laser. Thus, in the case of an enclosed laser system, the supply lines such as cables and hoses must be placed inside the enclosure without compromising the functionality of the safety interlock.

2.2 Installation position and space conditions

The device is designed for operation in horizontal position with a beam incidence from above. A flat surface is required to mount the unit. An orthogonal surface to the laser beam is necessary. Ensure sufficient space for the connecting cables and the travel range of the z-axis. Drawings with the dimensions of the device can be found on the following pages.

3 Required connections

For the operation of the device, a cooling water supply as well as a compressed air supply may be required. The device is equipped with a high-brilliance measuring objective, which must also be cooled with water and flushed with compressed air.

3.1 Cooling circuit requirements

3.1.1 Water quality

The device can be operated with tap water as well as demineralized water. An operation with strongly deionized water (DI-water, conductivity < 30 $\mu\text{S}/\text{cm}$) is only possible with appropriate connection parts (stainless steel) – we will be glad to advise you as necessary. Large dirt particles or teflon tape may block internal cooling circuits. Therefore, please thoroughly rinse the system before connecting it.

3.1.2 Aluminum components

No components made of aluminum must be installed in the cooling circuit.

3.1.3 Additive

Glycol or other antifreeze agents change the heat capacity of the cooling water, which is included in the calculation of the laser power. If larger amounts (> 1 %) of additives are added, the heat capacity changes noticeably, and so does the laser power display.

3.1.4 Parameters of the cooling water connection

Data	MSM+ HB10
PE hose diameter	12 mm
Recommended flow rate	7 - 8 l/min
Minimum flow rate	5 l/min
Recommended water pressure	2 bar
Maximum water pressure	4 bar

Tab. 3.1: Parameters of the cooling water connection

3.1.5 Condensates in the device

The device must not be operated in a condensing atmosphere. The humidity has to be considered in order to prevent condensates within and outside the device.

A sufficiently large cooling water reservoir is necessary for a stable cooling water temperature ($\Delta T < 1$ K/min). The temperature of the cooling water must not be below the dew point.

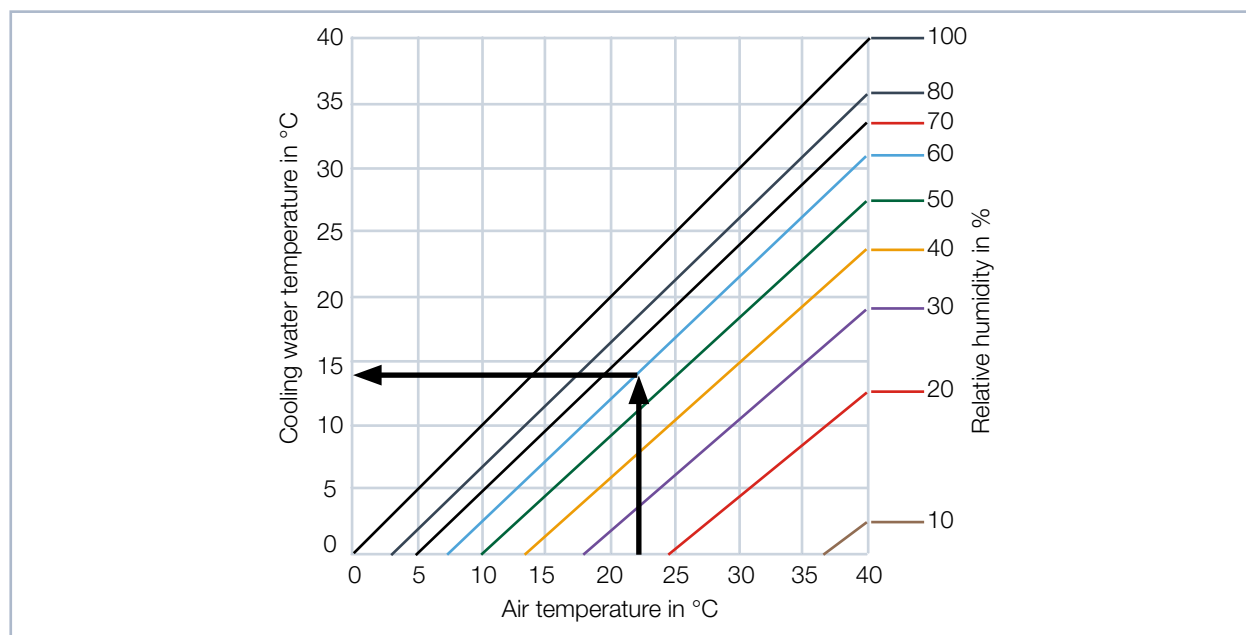

Tab. 3.2: Dew point diagram

Example:

Air temperature: 22 °C

Relative humidity: 60 %

The cooling water temperature must not fall below 14 °C.

3.1.6 Flow rate

The value for the flow rate should not be below 0.7 l/min per kW laser power.

The following rule of thumb can be used to determine the flow rate - depending on the laser power used: For each kW of laser power, a flow rate of approx. 1 l/min of cooling water is required.

Example:

At 7 kW laser power, this corresponds to a flow rate of 7 l/min.

3.2 Compressed air requirements

The compressed air is needed to create an outward rotating air flow in the HighBrilliance measuring objective, which is intended to prevent the ingress of dirt particles.

Compressed air connection parameters

Data	Value
Hose outer diameter	6 mm
Typical air pressure	0.5 to 1.0 bar
Maximum permissible pressure	2 bar
Purity level	ISO 8573-1:2010 [6:4:4] Cleaned, water and oil free

Tab. 3.3: Compressed air connection parameters

3.3 Electrical connections required

The following cables and connections are required to connect the device:

- 230 V / 16 A sockets for the 24 V power supply unit of the device
- Ethernet cable from PC to device
- Safety interlock connection cable

4 Environmental conditions

Environmental conditions	
Operating temperature range	+15 °C ... +40 °C (Reference temperature + 22 °C)
Permissible relative humidity (non-condensing)	80 %

5 Dimensions

The device can be traversed in the z-axis by 120 mm. The maximum height of the device is 425 mm.

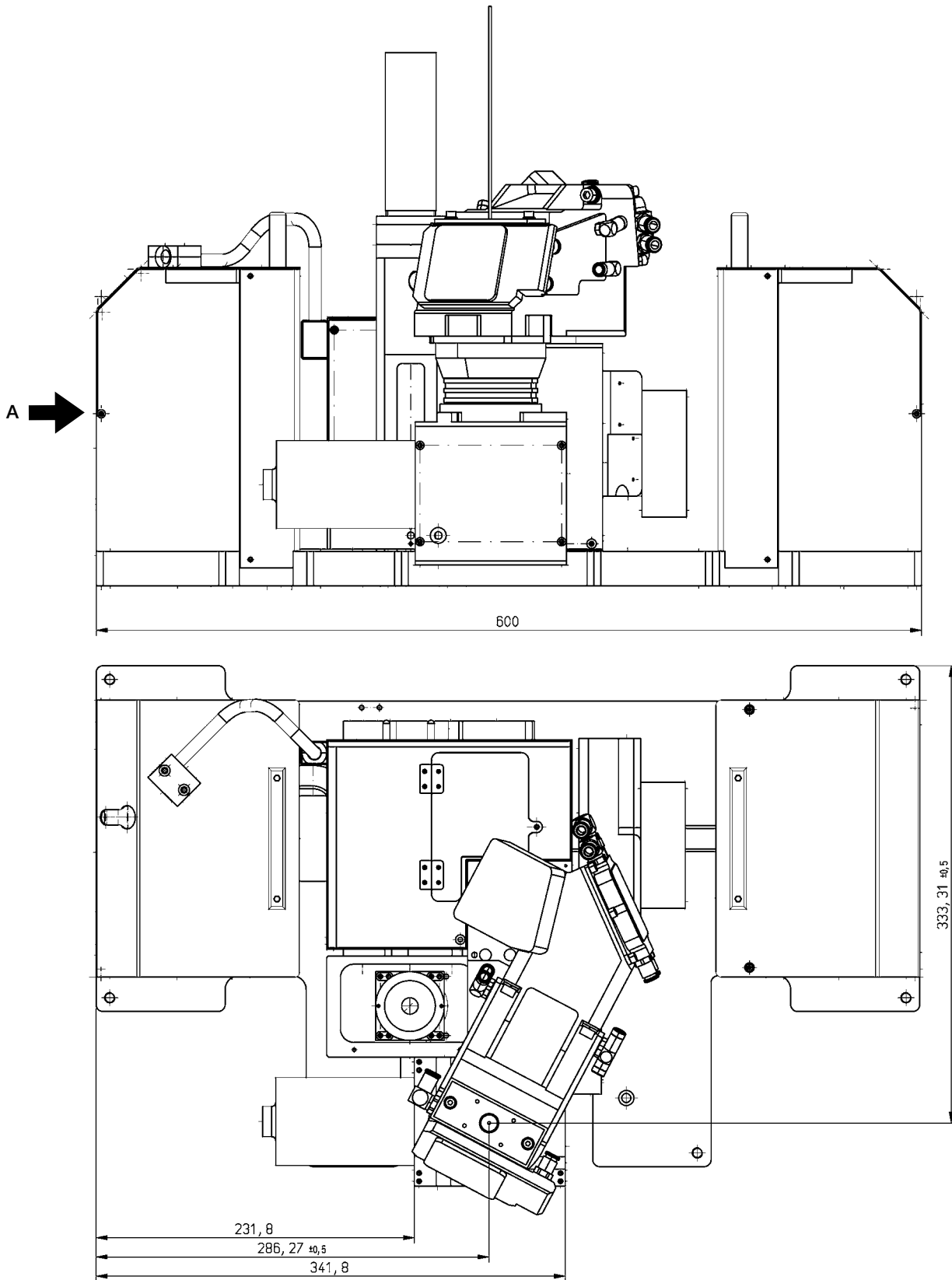

Dimensions in mm

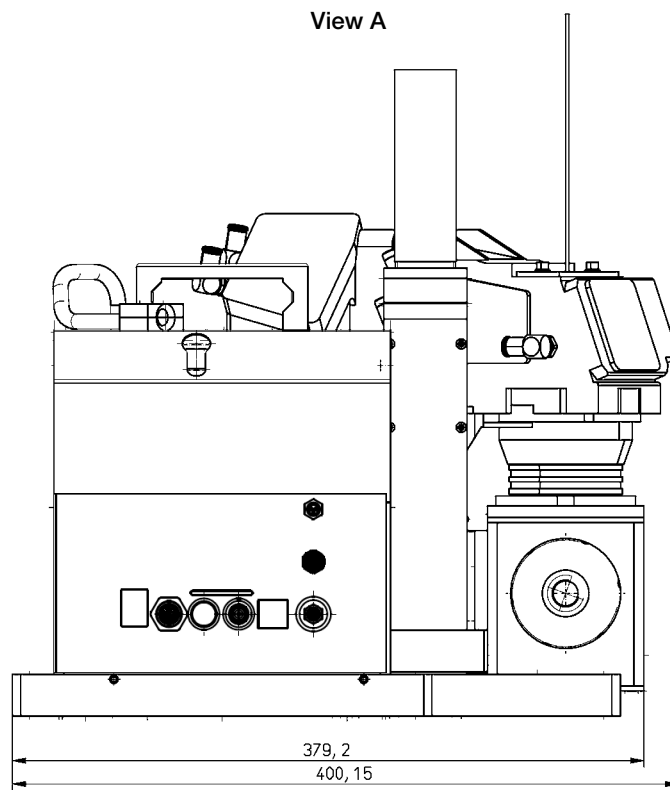

Dimensions in mm

PRIMES GmbH
Max-Planck-Str. 2
64319 Pfungstadt
Germany

Tel +49 6157 9878-0
info@primes.de
www.primes.de