

Preparations for the efficient performance of measurements by PRIMES



FocusMonitor FM+ with PowerMonitor PM 100

PRIMES - the company

PRIMES is a manufacturer of measuring devices which are used to analyze laser beams. These devices are employed for the diagnostics of high-power lasers ranging from CO₂-, fiber- and solid-state lasers to diode lasers. A wavelength range from infrared through to near UV is covered, offering a wide variety of measuring devices to determine the following beam parameters:

- Laser power
- Beam dimensions and position of an unfocused beam
- Beam dimensions and position of a focused beam
- Beam quality factor M²

Development, production and calibration of the measuring devices is performed at PRIMES. This guarantees optimum quality, excellent service, and a short reaction time, providing the basis for us to meet all of our customers' requirements quickly and reliably.



PRIMES GmbH
Max-Planck-Str. 2
64319 Pfungstadt
Germany

Tel +49 6157 9878-0
info@primes.de
www.primes.de

1 Safety is important to us

1.1 Personal protection equipment

In order to ensure the health of our employees, wearing personal protective equipment (PPE) is essential for many activities. Therefore, please inform us whether and what kind of personal protective equipment is required in your company.

1.2 Laser protection and safety regulations

In order to perform safe measurements, the place of operation must comply with the current laser protection and safety regulations. Please understand that we cannot perform the measurements if the safety precautions on site are inadequate.

2 Structural conditions

2.1 Safety Interlock

The safety interlock on the PowerMonitor PM 100 protects in the event of a fault by automatically switching off the laser. Thus, in the case of an enclosed laser system, the supply lines such as cables and hoses must be placed inside the enclosure without compromising the functionality of the safety interlock.

2.2 Installation position and space conditions

The device is designed for operation in horizontal position with a beam incidence from above. A flat surface is required to mount the unit. An orthogonal surface to the laser beam is necessary. Ensure sufficient space for the connecting cables and the travel range of the z-axis. Drawings with the dimensions of the device can be found on the following pages.

3 Required connections

For the operation of the PowerMonitor PM 100 a cooling water supply is required.

3.1 Cooling circuit requirements

3.1.1 Water quality

The PowerMonitor PM 100 can be operated with tap water as well as demineralized water. An operation with strongly deionized water (DI-water, conductivity < 30 $\mu\text{S}/\text{cm}$) is only possible with appropriate connection parts (stainless steel) – we will be glad to advise you as necessary. Large dirt particles or teflon tape may block internal cooling circuits. Therefore, please thoroughly rinse the system before connecting it.

3.1.2 Aluminum components

No components made of aluminum must be installed in the cooling circuit.

3.1.3 Additive

Glycol or other antifreeze agents change the heat capacity of the cooling water, which is included in the calculation of the laser power. If larger amounts (> 1 %) of additives are added, the heat capacity changes noticeably, and so does the laser power display.

3.1.4 Parameters of the cooling water connection

Data	PM 100
PE hose diameter	16 mm
Recommended flow rate	15 – 30 l/min
Minimum flow rate	8 l/min
Recommended water pressure	2 bar
Maximum water pressure	6 bar

Tab. 3.1: Parameters of the cooling water connection

3.1.5 Condensates in the device

The PowerMonitor PM 100 must not be operated in a condensing atmosphere. The humidity has to be considered in order to prevent condensates within and outside the device. A sufficiently large cooling water reservoir is necessary for a stable cooling water temperature ($\Delta T < 1$ K/min). The temperature of the cooling water must not be below the dew point.

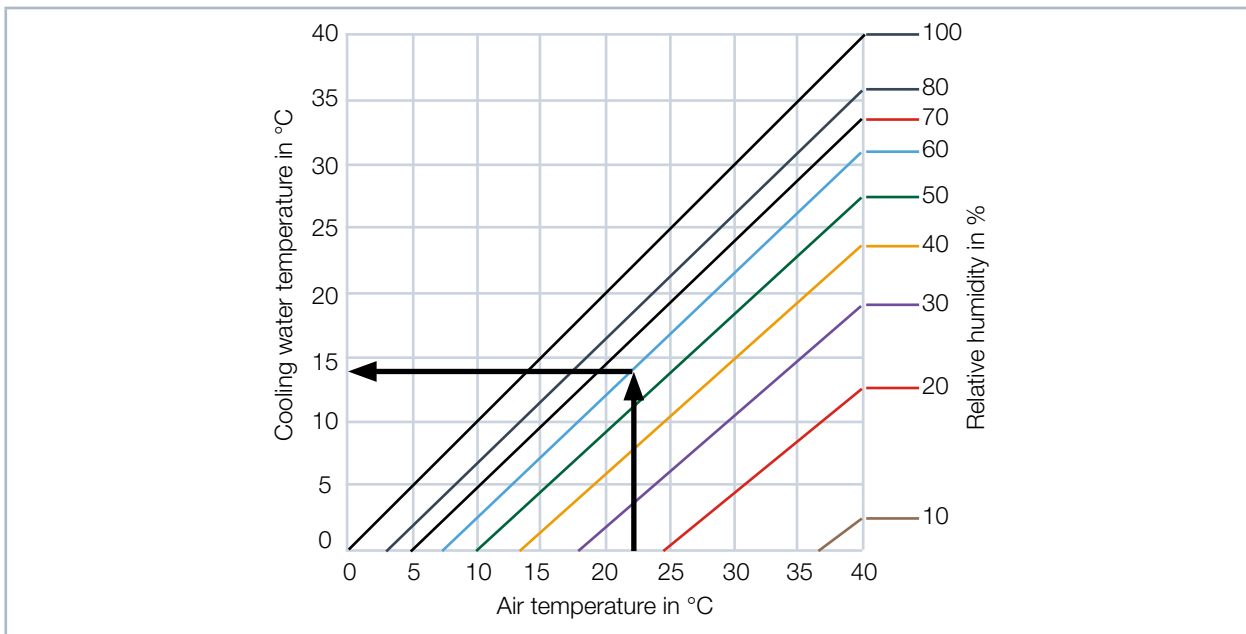

Tab. 3.2: Dew point diagram

Example:

Air temperature: 22 °C
 Relative humidity: 60 %

The cooling water temperature must not fall below 14 °C.

3.1.6 Flow rate

The value for the flow rate should not be below 0.7 l/min per kW laser power.

The following rule of thumb can be used to determine the flow rate - depending on the laser power used: For each kW of laser power, a flow rate of approx. 1 l/min of cooling water is required.

Example:

At 7 kW laser power, this corresponds to a flow rate of 7 l/min.

3.2 Electrical connections required

The following cables and connections are required to connect the device:

- 230 V / 16 A sockets for the 24 V power supply unit of the device
- Ethernet cable from PC to device
- Safety interlock connection cable

3.3 Inert gas for measuring very high power densities

When measuring high power densities ($\text{CO}_2 > 15 - 30 \text{ MW/cm}^2$; NIR $> 8 - 10 \text{ MW/cm}^2$), plasma may be ignited on the surface of the measuring tip of the FocusMonitor FM+.

In the case of high power densities, have an inert gas connection with helium, nitrogen or argon ready. The pressure must not exceed 0.5 bar. The inert gas connection is located on the FocusMonitor FM+.

4 Environmental conditions

Environmental conditions	
Operating temperature range	+15 °C ... +40 °C (Reference temperature + 22 °C)
Permissible relative humidity (non-condensing)	80 %

5 Dimensions

5.1 FocusMonitor FM+

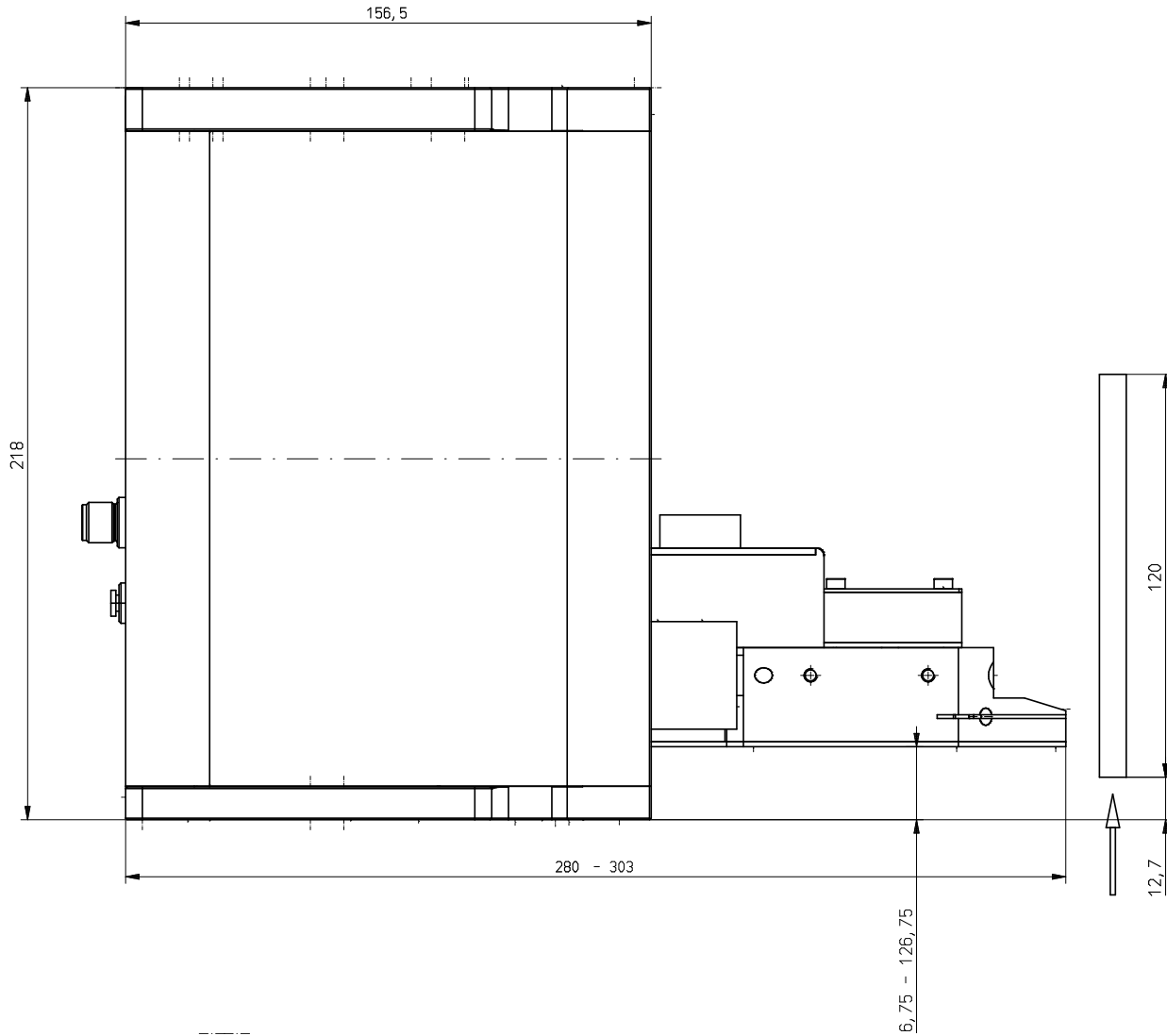

Dimensions in mm

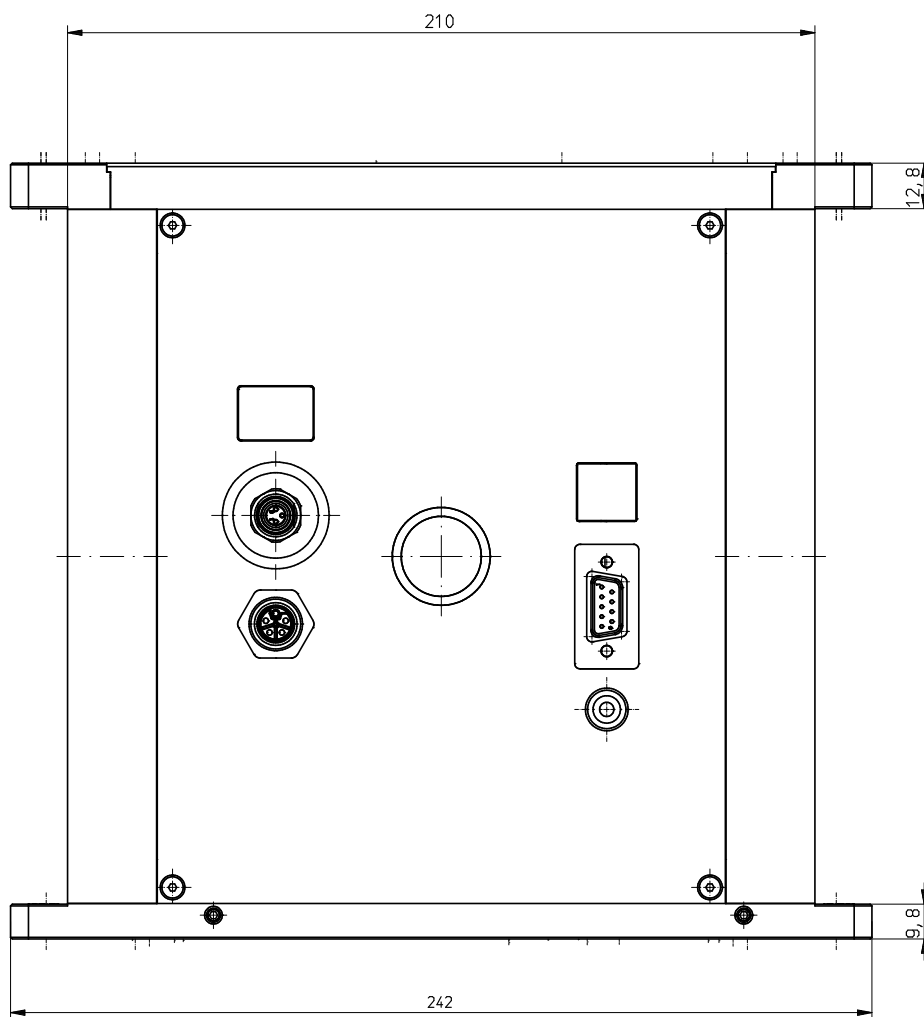

Dimensions in mm

5.2 PowerMonitor PM 100

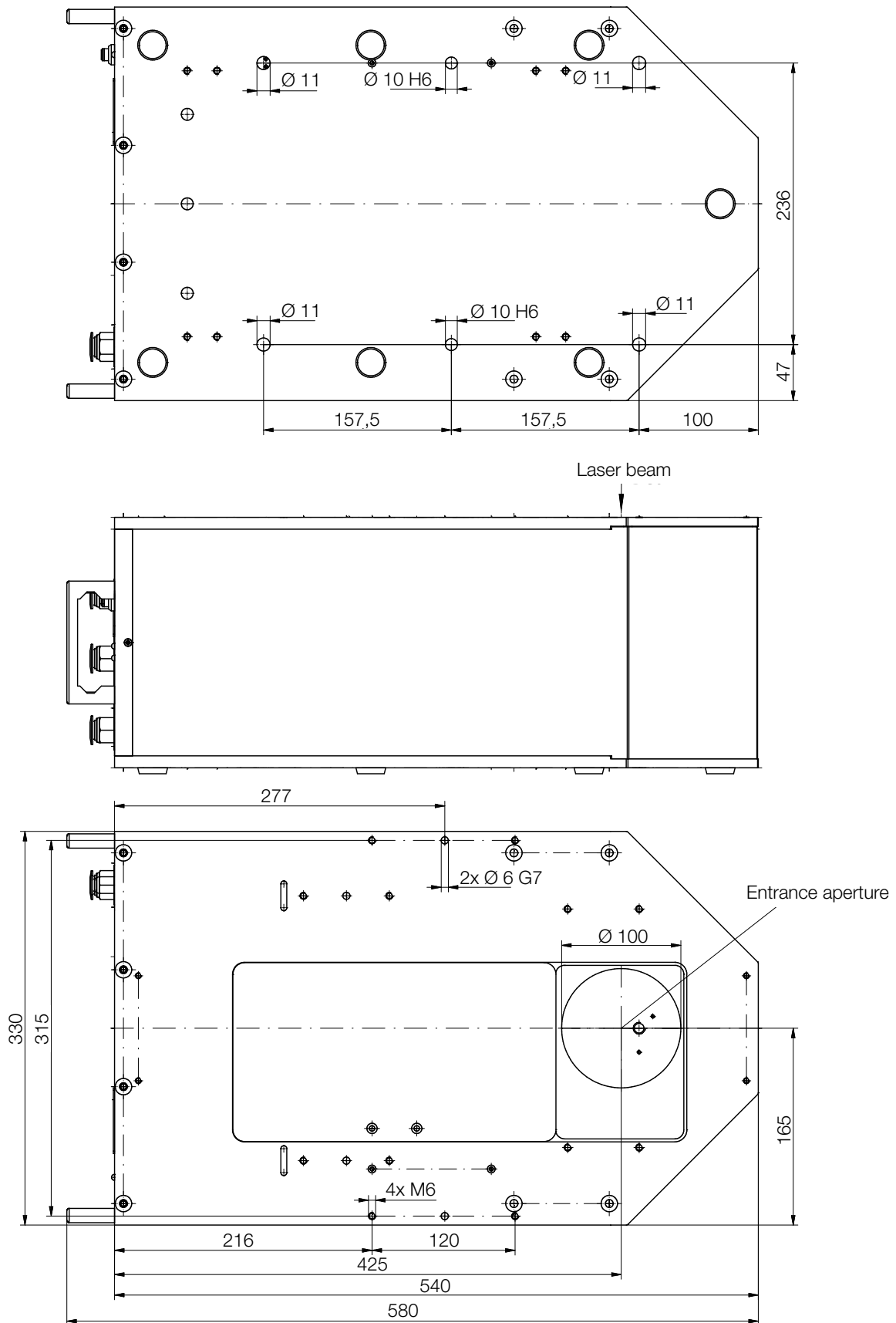

Dimensions in mm

5.3 Maximum height when using spacers

Depending on the beam parameters, it may be necessary to use spacers between the FocusMonitor FM+ and the PowerMonitor PM.



Abb. 5.1: Overview of the total height

Spacers	H in mm
A	461
B	546
C	646
D	886

Tab. 5.1: Mounting heights of the FocusMonitor FM+ with different spacers on the PowerMonitor PM 100

The total height includes the removable device feet of the PowerMonitor PM (device feet height = 5 mm).

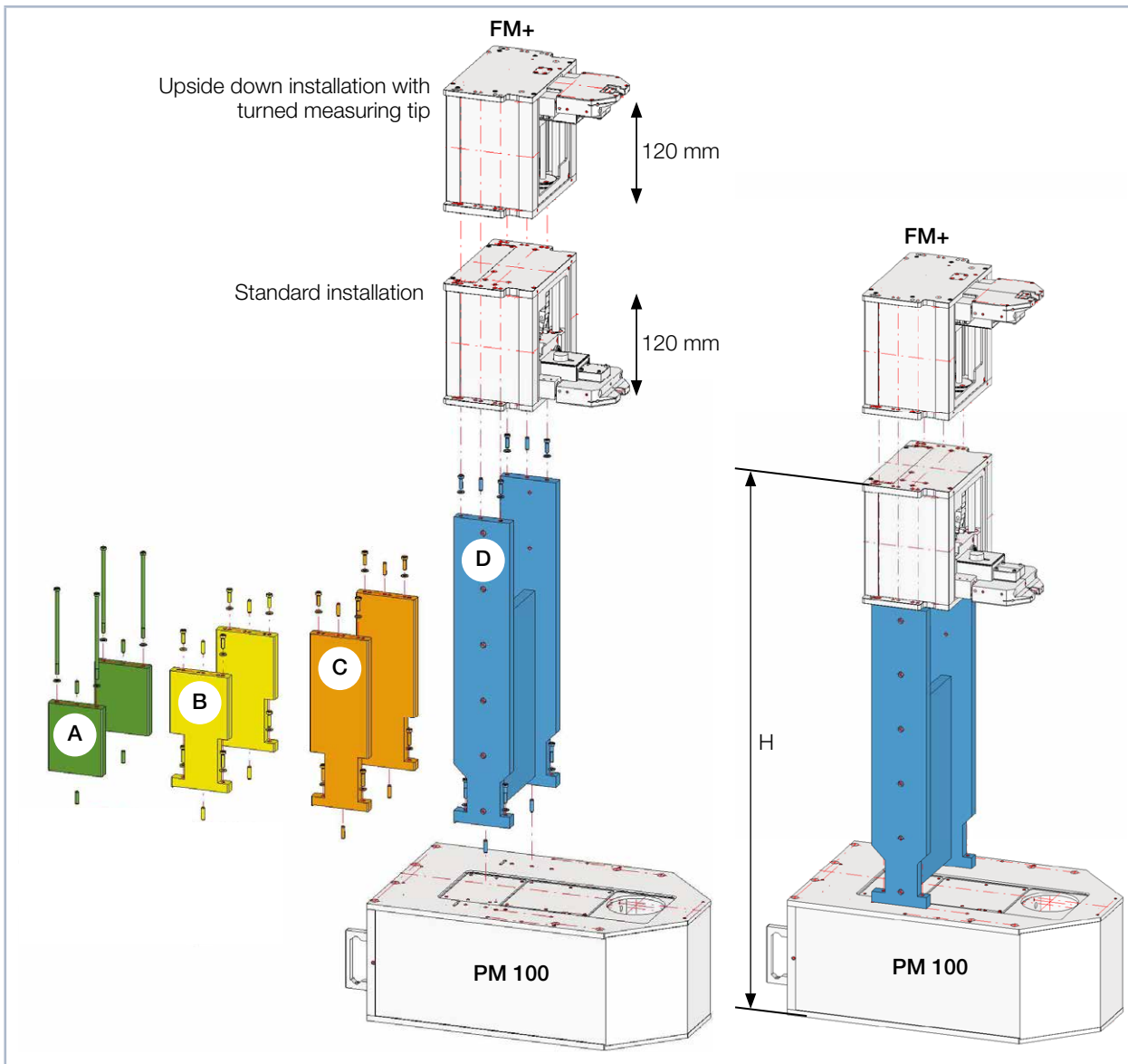
PRIMES GmbH
Max-Planck-Str. 2
64319 Pfungstadt
Germany

Tel +49 6157 9878-0
info@primes.de
www.primes.de